

## Round LED modules 220mm

### Product description

- Long life-time
- Built-in, constant current LED module
- Re-workable push-in terminals enabling easy connection
- Compliance and approval: CE, ENEC
- Available CCT from 2200K to 6500K and CRI 80, 90



### RdLED CRI 80 Optimum G2

Product name	Ordering code	Colour temperature [K]	Current nominal If nom [mA]	Luminous flux <sup>1</sup> φ [lm]	Useful luminous flux <sup>2</sup> [lm]	Voltage <sup>1</sup> Vf [V]	Power <sup>1</sup> P [W]	Efficacy <sup>1</sup> [lm/W]	Current minimum If min <sup>3</sup> [mA]	Current maximum If max [mA]	Energy Efficiency Class
RdLED 220mm 1500lm 830 24V EMG Opt G2	1010 117 87646	3000	370	1436	1481	21	7.9	181	80	1200	C
Emergency light			450	211	218	2.8	1.3	166	40	600	
RdLED 220mm 1500lm 840 24V EMG Opt G2	1010 117 87746	4000	370	1556	1605	21	7.9	196	80	1200	B
Emergency light			450	229	236	2.8	1.3	180	40	600	

### RdLED CRI 90 Optimum G2

Product name	Ordering code	Colour temperature [K]	Current nominal If nom [mA]	Luminous flux <sup>1</sup> φ [lm]	Useful luminous flux <sup>2</sup> [lm]	Voltage <sup>1</sup> Vf [V]	Power <sup>1</sup> P [W]	Efficacy <sup>1</sup> [lm/W]	Current minimum If min <sup>3</sup> [mA]	Current maximum If max [mA]	Energy Efficiency Class
RdLED 220mm 1500lm 927 24V EMG Opt G2	1010 117 42246	2700	420	1325	1373	22	9.3	143	80	1200	D
Emergency light			520	186	193	2.9	1.6	119	40	600	
RdLED 220mm 1500lm 927 24V EMG SSW Opt G2	1010 117 75846	2700	420	1325	1373	22	9.3	143	80	1200	D
Emergency light			520	186	193	3.0	1.6	119	40	600	
RdLED 220mm 1500lm 930 24V EMG Opt G2	1010 117 42346	3000	420	1423	1474	22	9.3	153	80	1200	D
Emergency light			520	200	208	2.9	1.6	128	40	600	
RdLED 220mm 1500lm 930 24V EMG SSW Opt G2	1010 117 50746	3000	420	1423	1474	22	9.3	153	80	1200	D
Emergency light			520	200	208	3.0	1.6	128	40	600	
RdLED 220mm 1500lm 940 24V EMG Opt G2	1010 117 42446	4000	420	1505	1576	22	9.3	162	80	1200	D
Emergency light			520	212	222	2.9	1.6	136	40	600	
RdLED 220mm 1500lm 940 24V EMG SSW Opt G2	1010 117 50846	4000	420	1521	1576	22	9.3	164	80	1200	D
Emergency light			420	178	222	3.0	1.2	143	40	600	

### RdLED CRI 80 Optimum

Product name	Ordering code	Colour temperature [K]	Current nominal If nom [mA]	Luminous flux <sup>1</sup> φ [lm]	Useful luminous flux <sup>2</sup> [lm]	Voltage <sup>1</sup> Vf [V]	Power <sup>1</sup> P [W]	Efficacy <sup>1</sup> [lm/W]	Current minimum If min <sup>3</sup> [mA]	Current maximum If max [mA]	Energy Efficiency Class
RdLED 220mm 1500lm 827-865 EMG 24V Optimum	1010 117 23046	2700	400	1486	1532	22	8.8	167	80	1200	C
Emergency light		6500	400	1609	1659	22	8.8	181	80	1200	
RdLED 220mm 1500lm 830 EMG 24V Optimum		1010 117 21946	3000	380	1501	1553	22	8.3	180	80	
Emergency light	380			180	186	2.8	1.1	166	40	600	
RdLED 220mm 1500lm 830 EMG SSW 24V Optimum	1010 117 22146	3000	380	1501	1553	22	8.3	180	80	1200	C
Emergency light			380	180	186	2.8	1.1	166	40	600	
RdLED 220mm 1500lm 840 EMG 24V Optimum	1010 117 22046	4000	380	1576	1631	22	8.3	189	80	1200	C
Emergency light			380	189	195	2.8	1.1	174	40	600	
RdLED 220mm 1500lm 840 EMG SSW 24V Optimum	1010 117 22246	4000	380	1576	1631	22	8.3	189	80	1200	C
Emergency light			380	189	195	2.8	1.1	174	40	600	

<sup>1</sup>At nominal current and T<sub>p</sub>

<sup>2</sup>At nominal current and 25°C

<sup>3</sup>It is recommended not to operate below minimum current in order to avoid un-even brightness

Tolerance range for optical and electrical ±10%

## Round LED modules 220mm

### Temperature & humidity

Specification item	Unit	Value
Tp	[°C]	45
Tp rated	[°C]	65
Tc	[°C]	85
Relative humidity (non-condensing)	[%]	5 ... 85
Storage ambient temperature	[°C]	-25 ... +85
Storage relative humidity (non-condensing)	[%]	5 ... 85

Tp - Temperature related to the performance parameters of the LED modules

Tp rated - Maximum operating temperature to which the rated performance characteristics are declared

Tc - Highest permissible value for safe operation

### Technical data

Specification item	Unit	Value
Classification acc. to IEC 62031		built-in
Working voltage	[Vdc]	350
Beam angle	[deg]	120
Initial color consistency	[SDCM]	3
Photobiological safety		RG1 unlimited

### Color coordinates

According to CIE 1931

Specification item	CIEx	CIEy
2700K	0.4578	0.4101
3000K	0.4338	0.4030
4000K	0.3818	0.3797
6500K	0.3123	0.3282

### Certificates & standards

Specification item	Compliant
ENEC	Yes
CE	Yes
RoHS	Yes
REACH	Yes
Zhaga	No
IP rating	No IP rating

### Lumen maintenance

#### RdLED CRI 80

#### RdLED CRI 90

Forward current	Tp temp.	L70 [h]		L80 [h]		L90 [h]	
		B50	B10	B50	B10	B50	B10
If nom	45°C	>102 000	>102 000	>102 000	>102 000	76 000	67 000
	55°C	>102 000	>102 000	>102 000	>102 000	76 000	67 000
	65°C	>102 000	>102 000	>102 000	>102 000	75 000	66 000
	75°C	>102 000	>102 000	>102 000	>102 000	74 000	65 000
	85°C	>102 000	>102 000	>102 000	>102 000	73 000	65 000
If max	45°C	>72 000	>72 000	>72 000	>72 000	49 000	37 000
	55°C	>72 000	>72 000	>72 000	>72 000	49 000	37 000
	65°C	>72 000	>72 000	>72 000	>72 000	49 000	36 000
	75°C	>72 000	>72 000	>72 000	>72 000	45 000	34 000
	85°C	>72 000	>72 000	>72 000	67 000	42 000	33 000

reported data based on LM80 LED data (@65mA 17000h / @160mA & 200mA 12000h)

Forward current	Tp temp.	L70 [h]		L80 [h]		L90 [h]	
		B50	B10	B50	B10	B50	B10
If nom	45°C	>60 000	>60 000	>60 000	>60 000	>60 000	>60 000
	65°C	>60 000	>60 000	>60 000	>60 000	58 000	57 000
If max	85°C	>60 000	>60 000	>60 000	>60 000	46 000	40 000
	45°C	>60 000	>60 000	52 000	49 000	29 000	28 000
If max	65°C	>60 000	>60 000	47 000	44 000	25 000	24 000
	85°C	>60 000	58 000	41 000	38 000	22 000	19 000

reported data based on LM80 LED data 10 000h

## Round LED modules 220mm

### RdLED CRI 80

for RdLED CRI 80 Optimum G2

Forward current	Tp temp.	L70 [h]		L80 [h]		L90 [h]	
		B50	B10	B50	B10	B50	B10
If nom	45°C	>60 000	>60 000	>60 000	>60 000	46 000	42 000
	65°C	>60 000	>60 000	>60 000	>60 000	36 000	30 000
	85°C	>60 000	>60 000	>60 000	>60 000	31 000	25 000
If max	45°C	>60 000	>60 000	>60 000	>60 000	40 000	32 000
	65°C	>60 000	>60 000	>60 000	>60 000	30 000	27 000
	85°C	>60 000	>60 000	>60 000	55 000	25 000	25 000

reported data based on LM80 LED data 10 000h

### Dimensions

RdLED 220mm

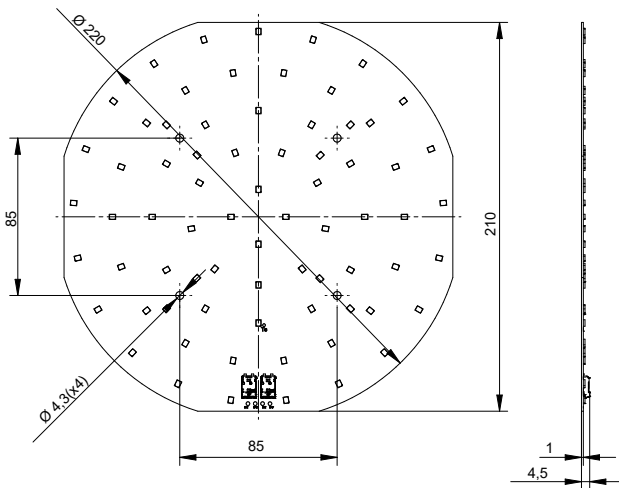

RdLED 220mm SSW

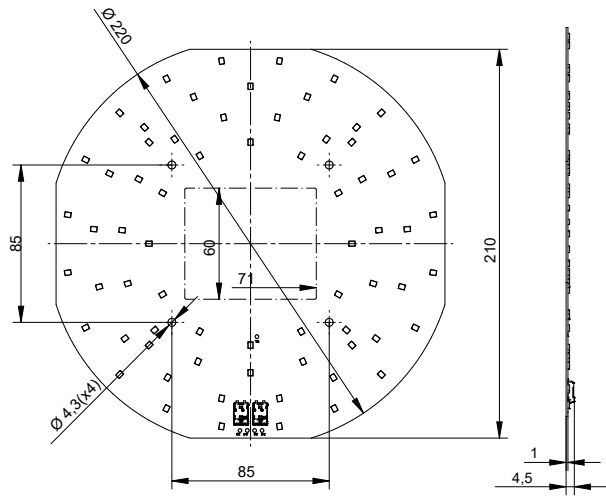

### Mounting

LED Modules cannot be exposed to tensile or compressive stresses. For this purpose it is necessary that the modules are assembled to a flat surface by only rounded head screws. Additionally plastic flat washer should be used to ensure creepage distance between screw's head and surface of the pcb. Max. torque for fixing: 0,5Nm.

LED modules are sensitive to electrostatic discharge (ESD). Follow safety regulations according to IEC 61340-5-1.

### Wiring

Wire cross section and strip length:

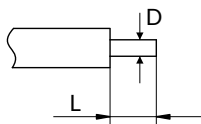

D - wire cross section (solid and flexible wires)	Min	Max
	0.2mm <sup>2</sup>	0.75mm <sup>2</sup>
	AWG 24	AWG 18

L - strip length	Min	Max
	8mm	9mm

Opening for the release of wires from the top with release pin Electroterminal art. 881 167 884:



## Round LED modules 220mm

### Connections

Wiring for parallel connection system

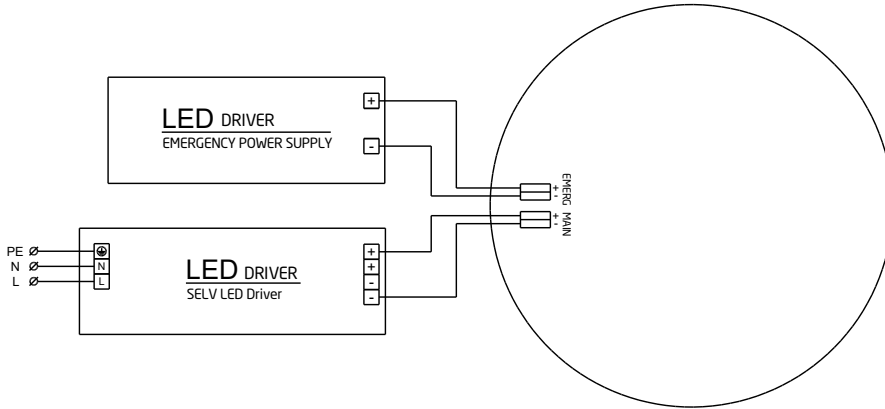

### Energy Label / EPREL database

To obtain Energy Label for this product visit <https://eprel.ec.europa.eu/> and enter model identifier

Model identifier consists of 10 digits XXXX XXX XXX. It is printed directly on the LED module or on product label. This is the number you can see in EPREL database.

Ordering code consist of 12 digits XXXX XXX XXX46. Additional last two digits means packaging of the product.

### Ordering codes

Product name	Ordering code	Pieces per box	Pieces per pallet	Box dimensions [mm]
RdLED 220mm 1500lm 830 24V EMG Opt G2	1010 117 87646	20	2100	238 x 238 x 91
RdLED 220mm 1500lm 840 24V EMG Opt G2	1010 117 87746	20	2100	238 x 238 x 91
RdLED 220mm 1500lm 927 24V EMG Opt G2	1010 117 42246	20	2100	238 x 238 x 91
RdLED 220mm 1500lm 927 24V EMG SSW Opt G2	1010 117 75846	20	2100	238 x 238 x 91
RdLED 220mm 1500lm 930 24V EMG Opt G2	1010 117 42346	20	2100	238 x 238 x 91
RdLED 220mm 1500lm 930 24V EMG SSW Opt G2	1010 117 50746	20	2100	238 x 238 x 91
RdLED 220mm 1500lm 940 24V EMG Opt G2	1010 117 42446	20	2100	238 x 238 x 91
RdLED 220mm 1500lm 940 24V EMG SSW Opt G2	1010 117 50846	20	2100	238 x 238 x 91
RdLED 220mm 1500lm 827-865 EMG 24V Optimum	1010 117 23046	20	2100	238 x 238 x 91
RdLED 220mm 1500lm 830 EMG 24V Optimum	1010 117 21946	20	2100	238 x 238 x 91
RdLED 220mm 1500lm 830 EMG SSW 24V Optimum	1010 117 22146	20	2100	238 x 238 x 91
RdLED 220mm 1500lm 840 EMG 24V Optimum	1010 117 22046	20	2100	238 x 238 x 91
RdLED 220mm 1500lm 840 EMG SSW 24V Optimum	1010 117 22246	20	2100	238 x 238 x 91