

Round LED modules 400mm

Product description

- Long life-time
- Built-in, constant current LED module
- Re-workable push-in terminals enabling easy connection
- Compliance and approval: CE, ENEC
- Available CCT from 2700K to 6500K and CRI 80, 90



RdLED CRI 80 Optimum G2

Product name	Ordering code	Colour temperature [K]	Current nominal If nom [mA]	Luminous flux ¹ ϕ [lm]	Useful luminous flux ² [lm]	Voltage ¹ Vf [V]	Power ¹ P [W]	Efficacy ¹ [lm/W]	Current minimum If min ³ [mA]	Current maximum If max [mA]	Energy Efficiency Class
RdLED 400mm 4000lm 830 105V Opt G2	1010 117 90446	3000	225	3860	3994	98	22	176	40	600	C
RdLED 400mm 4000lm 830 42V Opt G2	1010 117 90646		565	3877	4011	39	22	175	100	1500	C
RdLED 400mm 4000lm 840 105V Opt G2	1010 117 90546	4000	225	4055	4195	98	22	184	40	600	C
RdLED 400mm 4000lm 840 42V Opt G2	1010 117 90746		565	4072	4213	39	22	184	100	1500	C

RdLED CRI 90 Optimum G2

Product name	Ordering code	Colour temperature [K]	Current nominal If nom [mA]	Luminous flux ¹ ϕ [lm]	Useful luminous flux ² [lm]	Voltage ¹ Vf [V]	Power ¹ P [W]	Efficacy ¹ [lm/W]	Current minimum If min ³ [mA]	Current maximum If max [mA]	Energy Efficiency Class
RdLED 400mm 4000lm 930 42V Opt G2	1010 127 34246	3000	650	3926	4069	39	26	154	100	1500	D
RdLED 400mm 4000lm 940 42V Opt G2	1010 127 34346	4000	650	3926	4204	39	26	159	100	1500	D

RdLED CRI 80 Optimum G1

Product name	Ordering code	Colour temperature [K]	Current nominal If nom [mA]	Luminous flux ¹ ϕ [lm]	Useful luminous flux ² [lm]	Voltage ¹ Vf [V]	Power ¹ P [W]	Efficacy ¹ [lm/W]	Current minimum If min ³ [mA]	Current maximum If max [mA]	Energy Efficiency Class
RdLED 400mm 4200lm 827-865 33V Opt G1	1010 117 41746	2700	780	4022	4161	31	24	167	120	1800	D
		6500	780	4350	4500	31	24	180	120	1800	

RdLED CRI 90 Optimum G1

Product name	Ordering code	Colour temperature [K]	Current nominal If nom [mA]	Luminous flux ¹ ϕ [lm]	Useful luminous flux ² [lm]	Voltage ¹ Vf [V]	Power ¹ P [W]	Efficacy ¹ [lm/W]	Current minimum If min ³ [mA]	Current maximum If max [mA]	Energy Efficiency Class
RdLED 400mm 4200lm 927-965 33V Opt G1	1010 127 72946	2700	820	3620	3752	31	26	142	120	1800	E
		6500	820	4008	4154	31	26	157	120	1800	

¹At nominal current and T_p

²At nominal current and 25°C

³It is recommended not to operate below minimum current in order to avoid un-even brightness

Tolerance range for optical and electrical $\pm 10\%$

Temperature & humidity

Specification item	Unit	Value
T _p	[°C]	45
T _{p rated}	[°C]	65
T _c	[°C]	85
Relative humidity (non-condensing)	[%]	5 ... 85
Storage ambient temperature	[°C]	-25 ... +85
Storage relative humidity (non-condensing)	[%]	5 ... 85

T_p - Temperature related to the performance parameters of the LED modules

T_{p rated} - Maximum operating temperature to which the rated performance characteristics are declared

T_c - Highest permissible value for safe operation

Round LED modules 400mm

Technical data

Specification item	Unit	Value
Classification acc. to IEC 62031		built-in
Working voltage	[Vdc]	350
Beam angle	[deg]	120
Initial color consistency	[SDCM]	3
Photobiological safety		RG1 unlimited

Color coordinates

According to CIE 1931

Specification item	CIE _x	CIE _y
2700K	0.4578	0.4101
3000K	0.4338	0.4030
4000K	0.3818	0.3797
6500K	0.3123	0.3282

Certificates & standards

Specification item	Compliant
ENEC	Yes
CE	Yes
RoHS	Yes
REACH	Yes
Zhaga	No
IP rating	No IP rating

Lumen maintenance

RdLED CRI 80

for Opt G2

Forward current	Tp temp.	L70 [h]		L80 [h]		L90 [h]	
		B50	B10	B50	B10	B50	B10
If nom	45°C	>102 000	>102 000	>102 000	>102 000	74 000	64 000
	55°C	>102 000	>102 000	>102 000	>102 000	74 000	64 000
	65°C	>102 000	>102 000	>102 000	>102 000	73 000	64 000
	75°C	>102 000	>102 000	>102 000	>102 000	72 000	63 000
	85°C	>102 000	>102 000	>102 000	>102 000	71 000	62 000
If max	45°C	>72 000	>72 000	>72 000	>72 000	51 000	39 000
	55°C	>72 000	>72 000	>72 000	>72 000	51 000	39 000
	65°C	>72 000	>72 000	>72 000	>72 000	48 000	37 000
	75°C	>72 000	>72 000	>72 000	>72 000	45 000	35 000
	85°C	>72 000	>72 000	>72 000	69 000	43 000	34 000

reported data based on LM80 LED data (@65mA 17000h / @160mA & 200mA 12000h)

RdLED CRI 80

for Opt G1

Forward current	Tp temp.	L70 [h]		L80 [h]		L90 [h]	
		B50	B10	B50	B10	B50	B10
If nom	45°C	>102 000	>102 000	>102 000	>102 000	72 000	62 000
	55°C	>102 000	>102 000	>102 000	>102 000	72 000	62 000
	65°C	>102 000	>102 000	>102 000	>102 000	7 000	61 000
	75°C	>102 000	>102 000	>102 000	>102 000	69 000	60 000
	85°C	>102 000	>102 000	>102 000	>102 000	68 000	60 000
If max	45°C	>72 000	>72 000	>72 000	>72 000	51 000	39 000
	55°C	>72 000	>72 000	>72 000	>72 000	51 000	39 000
	65°C	>72 000	>72 000	>72 000	>72 000	48 000	37 000
	75°C	>72 000	>72 000	>72 000	>72 000	45 000	35 000
	85°C	>72 000	>72 000	>72 000	69 000	43 000	34 000

reported data based on LM80 LED data (@65mA 17000h / @160mA & 200mA 12000h)

RdLED CRI 90

for Opt G2

Forward current	Tp temp.	L70 [h]		L80 [h]		L90 [h]	
		B50	B10	B50	B10	B50	B10
If nom	45°C	>60 000	>60 000	>60 000	>60 000	>60 000	>60 000
	65°C	>60 000	>60 000	>60 000	>60 000	54 000	53 000
	85°C	>60 000	>60 000	>60 000	>60 000	43 000	38 000
	45°C	>60 000	>60 000	52 000	49 000	29 000	28 000
If max	65°C	>60 000	>60 000	47 000	44 000	25 000	24 000
	85°C	>60 000	58 000	41 000	38 000	22 000	19 000

reported data based on LM80 LED data (@65mA 10000h)

RdLED CRI 90

for Opt G1

Forward current	Tp temp.	L70 [h]		L80 [h]		L90 [h]	
		B50	B10	B50	B10	B50	B10
If nom	45°C	>60 000	>60 000	>60 000	>60 000	>60 000	>60 000
	65°C	>60 000	>60 000	>60 000	>60 000	52 000	51 000
	85°C	>60 000	>60 000	>60 000	>60 000	42 000	37 000
	45°C	>60 000	>60 000	52 000	49 000	29 000	28 000
If max	65°C	>60 000	>60 000	47 000	44 000	25 000	24 000
	85°C	>60 000	58 000	41 000	38 000	22 000	19 000

reported data based on LM80 LED data (@65mA 10000h)

Round LED modules 400mm

Dimensions

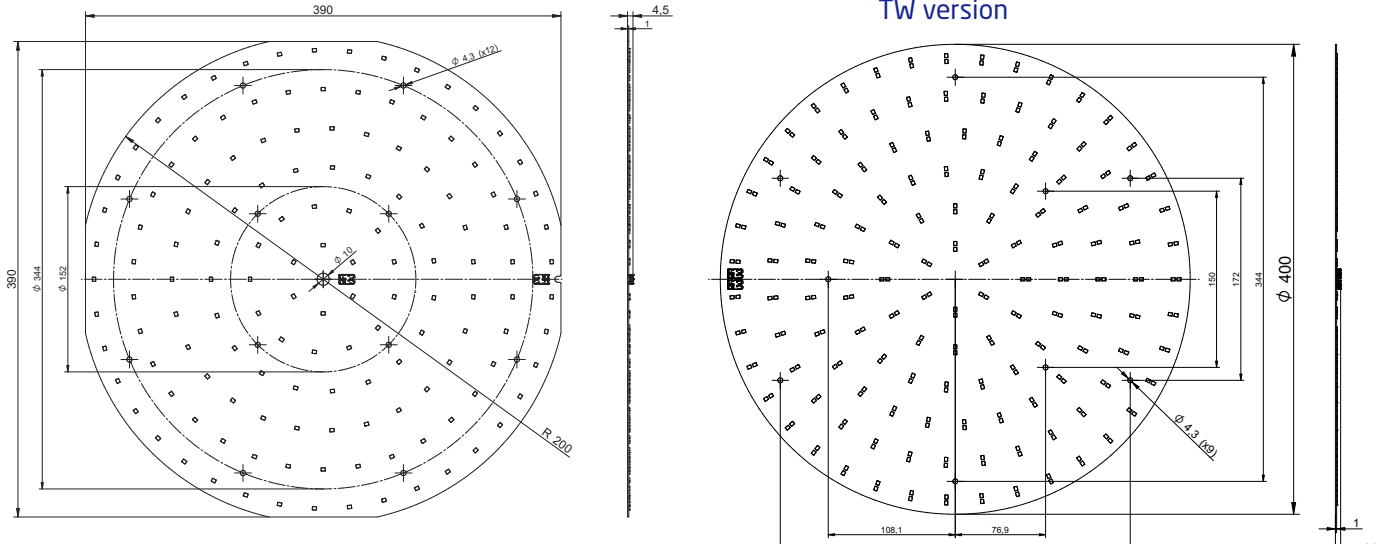

Mounting

LED Modules cannot be exposed to tensile or compressive stresses. For this purpose it is necessary that the modules are assembled to a flat surface by only rounded head screws. Additionally plastic flat washer should be used to ensure creepage distance between screw's head and surface of the pcb. Max. torque for fixing: 0,5Nm.

LED modules are sensitive to electrostatic discharge (ESD). Follow safety regulations according to IEC 61340-5-1.

Wiring

Wire cross section and strip length:

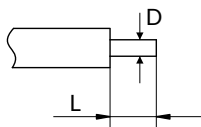

D - wire cross section (solid and flexible wires)	Min	Max
	0.2mm ²	0.75mm ²
	AWG 24	AWG 18

L - strip length	Min	Max
	8mm	9mm

Opening for the release of wires from the top with release pin Electroterminal art. 881 167 884:



Round LED modules 400mm

Connections

Wiring for series connection system

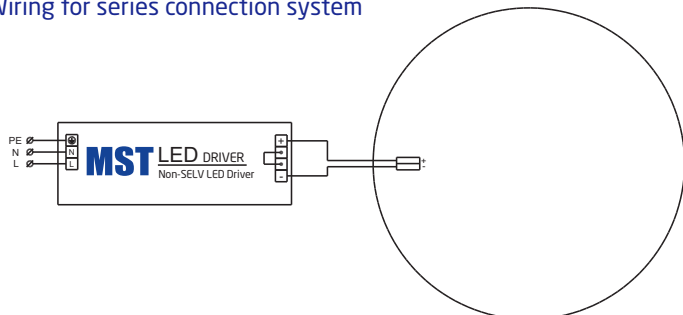

Wiring for parallel connection system

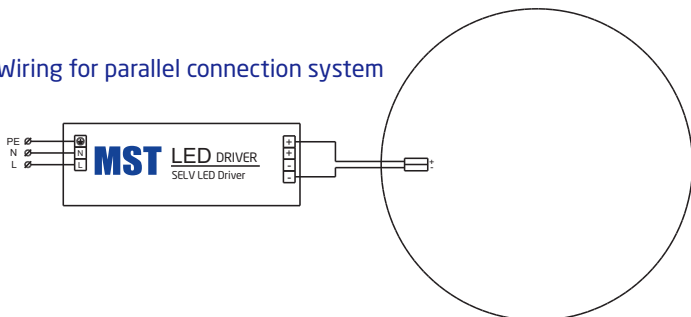

Wiring for TW version

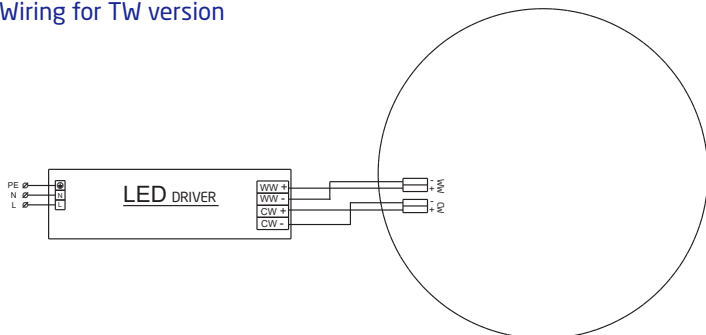

Energy Label / EPREL database

To obtain Energy Label for this product visit <https://eprel.ec.europa.eu/> and enter model identifier

Model identifier consists of 10 digits XXXX XXX XXX. It is printed directly on the LED module or on product label. This is the number you can see in EPREL database.

Ordering code consist of 12 digits XXXX XXX XXX46. Additional last two digits means packaging of the product.

Ordering codes

Product name	Ordering code	Pieces per box	Pieces per pallet	Box dimensions [mm]
RdLED 400mm 4000lm 830 105V Opt G2	1010 117 90446	12	336	413 x 413 x 58
RdLED 400mm 4000lm 830 42V Opt G2	1010 117 90646	12	336	413 x 413 x 58
RdLED 400mm 4000lm 840 105V Opt G2	1010 117 90546	12	336	413 x 413 x 58
RdLED 400mm 4000lm 840 42V Opt G2	1010 117 90746	12	336	413 x 413 x 58
RdLED 400mm 4000lm 930 42V Opt G2	1010 127 34246	12	336	413 x 413 x 58
RdLED 400mm 4000lm 940 42V Opt G2	1010 127 34346	12	336	413 x 413 x 58
RdLED 400mm 4200lm 827-865 33V Opt G1	1010 117 41746	12	336	413 x 413 x 58
RdLED 400mm 4200lm 927-965 33V Opt G1	1010 127 72946	12	336	413 x 413 x 58