

## Linear LED modules 156x28mm DAISY-4x1

A linear solution for premium class indoor lighting. Optimized for LEDi's DAISY-4x1 optics.

### Product description

- Long life-time
- Built-in, constant current LED module
- Re-workable push-in terminals enabling easy connection
- Compliance and approval: CE, ENEC
- 2C - two connectors for series system, also recognized as a high voltage system - non-SELV
- Available CCT from 2700K to 6500K and CRI 80, 90



The image shows version 2C. The number of connectors may vary depending on the type of module.



### LinLED CRI 80 Optimum G1

Product name	Ordering code	Colour temperature [K]	Current nominal If nom [mA]	Luminous flux <sup>2</sup> φ [lm]	Useful luminous flux <sup>2</sup> [lm]	Voltage <sup>1</sup> Vf [V]	Power <sup>1</sup> P [W]	Efficacy <sup>1</sup> [lm/W]	Current minimum If min <sup>3</sup> [mA]	Current maximum If max [mA]	Energy Efficiency Class
LinLED 156x28mm 2x200lm 827-865 2x2C 12V Opt G1	1010 117 46746	2700	110	193	199	12	1.3	151	40	150	D
		6500	110	209	215	12	1.3	163	40	150	
LinLED 156x28mm 2x400lm 827-865 2x2C 12V Opt G1	1010 117 49846	2700	220	386	398	12	2.6	151	40	300	D
		6500	220	418	430	12	2.6	163	40	300	
LinLED 156x28mm 400lm 830 2C 12V Opt G1	1010 117 46846	3000	220	397	410	12	2.6	155	40	300	D
LinLED 156x28mm 800lm 830 2C 12V Opt G1	1010 117 49946		440	794	819	12	5.1	155	40	600	D
LinLED 156x28mm 400lm 840 2C 12V Opt G1	1010 117 46946	4000	220	418	430	12	2.6	163	40	300	D
LinLED 156x28mm 800lm 840 2C 12V Opt G1	1010 117 50046		440	835	861	12	5.1	163	40	600	D

### LinLED CRI 90 Optimum G1

Product name	Ordering code	Colour temperature [K]	Current nominal If nom [mA]	Luminous flux <sup>2</sup> φ [lm]	Useful luminous flux <sup>2</sup> [lm]	Voltage <sup>1</sup> Vf [V]	Power <sup>1</sup> P [W]	Efficacy <sup>1</sup> [lm/W]	Current minimum If min <sup>3</sup> [mA]	Current maximum If max [mA]	Energy Efficiency Class
LinLED 156x28mm 2x400lm 927-965 2x2C 12V Opt G1	1010 117 65446	2700	260	373	386	12	3.1	119	40	300	E
		6500	260	428	444	12	3.1	137	40	300	
LinLED 156x28mm 800lm 930 2C 12V Opt G1	1010 127 07046	3000	485	754	781	12	5.8	130	40	600	E
LinLED 156x28mm 800lm 940 2C 12V Opt G1	1010 117 75446	4000	485	806	835	12	5.8	139	40	600	E

<sup>1</sup>At nominal current and T<sub>p</sub>

<sup>2</sup>At nominal current and 25°C

<sup>3</sup>It is recommended not to operate below minimum current in order to avoid un-even brightness

Tolerance range for optical and electrical ±10%

### Temperature & humidity

Specification item	Unit	Value
T <sub>p</sub>	[°C]	45
T <sub>p</sub> rated	[°C]	65
T <sub>c</sub>	[°C]	85
Relative humidity (non-condensing)	[%]	5 ... 85
Storage ambient temperature	[°C]	-25 ... +85
Storage relative humidity (non-condensing)	[%]	5 ... 85

T<sub>p</sub> - Temperature related to the performance parameters of the LED modules

T<sub>p</sub> rated - Maximum operating temperature to which the rated performance characteristics are declared

T<sub>c</sub> - Highest permissible value for safe operation

## Linear LED modules 156x28mm DAISY-4x1

### Technical data

Specification item	Unit	Value
Classification acc. to IEC 62031		built-in
Working voltage	[Vdc]	120
Beam angle	[deg]	120
Initial color consistency	[SDCM]	3
Photobiological safety		RG1 unlimited

### Color coordinates

According to CIE 1931

Specification item	CIEx	CIEy
2700K	0.4578	0.4101
3000K	0.4338	0.4030
4000K	0.3818	0.3797
6500K	0.3123	0.3282

### Certificates & standards

Specification item	Compliant
ENEC	Yes
CE	Yes
RoHS	Yes
REACH	Yes
Zhaga	No
IP rating	No IP rating

### Lumen maintenance

### LinLED CRI 80

Forward current	Tp temp.	L70 [h]		L80 [h]		L90 [h]	
		B50	B10	B50	B10	B50	B10
If nom	45°C	>72 000	>72 000	>72 000	>72 000	61 000	50 000
	55°C	>72 000	>72 000	>72 000	>72 000	61 000	50 000
	65°C	>72 000	>72 000	>72 000	>72 000	58 000	48 000
	75°C	>72 000	>72 000	>72 000	>72 000	56 000	47 000
	85°C	>72 000	>72 000	>72 000	>72 000	55 000	46 000
If max	45°C	>72 000	>72 000	>72 000	>72 000	51 000	39 000
	55°C	>72 000	>72 000	>72 000	>72 000	51 000	39 000
	65°C	>72 000	>72 000	>72 000	>72 000	48 000	37 000
	75°C	>72 000	>72 000	>72 000	>72 000	45 000	35 000
	85°C	>72 000	>72 000	>72 000	69 000	43 000	34 000

reported data based on LM80 LED data (@65mA 17000h / @160mA & 200mA 12000h)

### LinLED CRI 80

Forward current	Tp temp.	L70 [h]		L80 [h]		L90 [h]	
		B50	B10	B50	B10	B50	B10
If nom	45°C	>60 000	>60 000	>60 000	>60 000	38 000	37 000
	55°C	>60 000	>60 000	>60 000	58 000	32 000	30 000
If max	65°C	>60 000	>60 000	52 000	48 000	26 000	24 000
	45°C	>60 000	>60 000	52 000	49 000	29 000	28 000
	55°C	>60 000	>60 000	47 000	44 000	25 000	24 000
	65°C	>60 000	58 000	41 000	38 000	22 000	19 000

reported data based on LM80 LED data (10 000h)

## Linear LED modules 156x28mm DAISY-4x1

### Dimensions

Product name	Ordering code	Connectors (*)
LinLED 156x28mm 2x200lm 827-865 2x2C 12V Opt G1	1010 117 46746	Yes
LinLED 156x28mm 2x400lm 827-865 2x2C 12V Opt G1	1010 117 49846	Yes
LinLED 156x28mm 400lm 830 2C 12V Opt G1	1010 117 46846	No
LinLED 156x28mm 800lm 830 2C 12V Opt G1	1010 117 49946	No
LinLED 156x28mm 400lm 840 2C 12V Opt G1	1010 117 46946	No
LinLED 156x28mm 800lm 840 2C 12V Opt G1	1010 117 50046	No
LinLED 156x28mm 2x400lm 927-965 2x2C 12V Opt G1	1010 117 65446	Yes
LinLED 156x28mm 800lm 930 2C 12V Opt G1	1010 127 07046	No
LinLED 156x28mm 800lm 940 2C 12V Opt G1	1010 117 75446	No

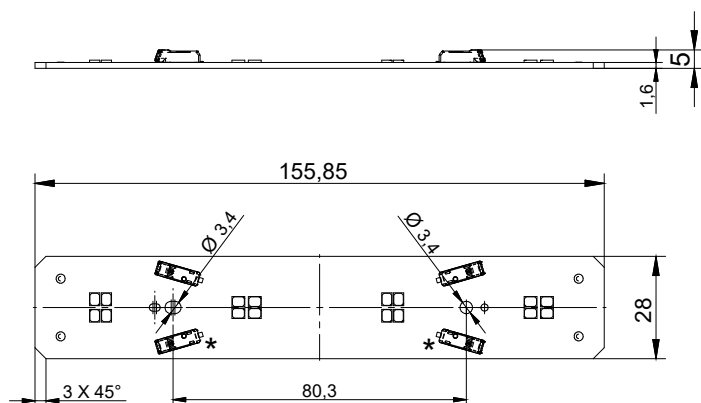

### Mounting

LED Modules cannot be exposed to tensile or compressive stresses. For this purpose it is necessary that the modules are assembled to a flat surface by only rounded head screws. Additionally plastic flat washer should be used to ensure creepage distance between screw's head and surface of the pcb. Max. torque for fixing: 0,5Nm.

LED modules are sensitive to electrostatic discharge (ESD). Follow safety regulations according to IEC 61340-5-1.

### Wiring

Wire cross section and strip length:

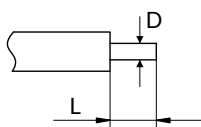

D - wire cross section (solid and flexible wires)	Min	Max
	0.13mm <sup>2</sup>	0.8mm <sup>2</sup>
	AWG 26	AWG 18

L - strip length	Min	Max
	4mm	5mm

Opening for the release of wires with contact opening tool AVX art. 06-9296-7001-01-000:

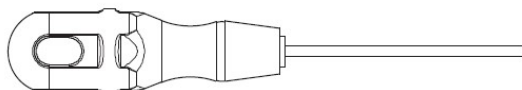

## Linear LED modules 156x28mm DAISY-4x1

### Connections

Max number of modules	Unit	Series	Parallel
LinLED 156x28mm...	[pcs]	23	-

#### Wiring for series connection system (2C)

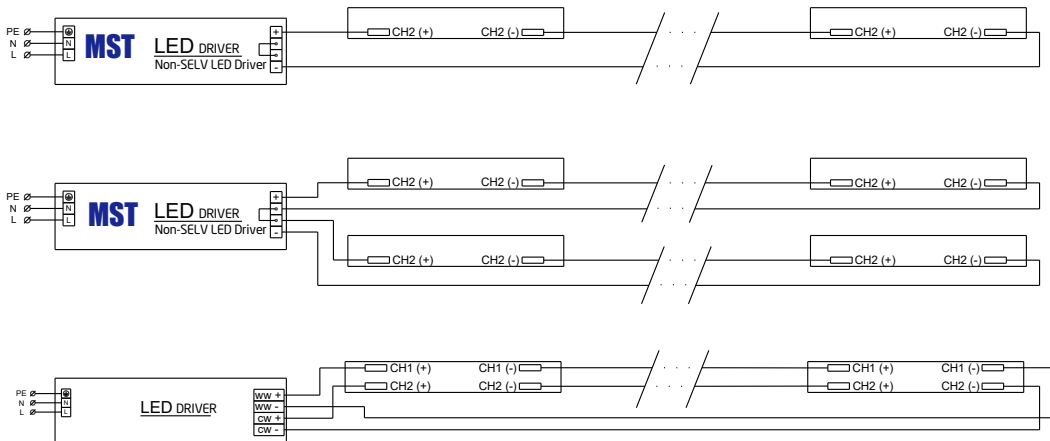

### Energy Label / EPREL database

To obtain Energy Label for this product visit <https://eprel.ec.europa.eu/> and enter model identifier

Model identifier consists of 10 digits XXXX XXX XXX. It is printed directly on the LED module or on product label. This is the number you can see in EPREL database.

Ordering code consist of 12 digits XXXX XXX XXX46. Additional last two digits means packaging of the product.

### Ordering codes

Product name	Ordering code	Pieces per box	Pieces per pallet	Box dimensions [mm]
LinLED 156x28mm 2x200lm 827-865 2x2C 12V Opt G1	1010 117 46746	96	18240	248 x 175 x 66
LinLED 156x28mm 2x400lm 827-865 2x2C 12V Opt G1	1010 117 49846	96	18240	248 x 175 x 66
LinLED 156x28mm 400lm 830 2C 12V Opt G1	1010 117 46846	96	18240	248 x 175 x 66
LinLED 156x28mm 800lm 830 2C 12V Opt G1	1010 117 49946	96	18240	248 x 175 x 66
LinLED 156x28mm 400lm 840 2C 12V Opt G1	1010 117 46946	96	18240	248 x 175 x 66
LinLED 156x28mm 800lm 840 2C 12V Opt G1	1010 117 50046	96	18240	248 x 175 x 66
LinLED 156x28mm 2x400lm 927-965 2x2C 12V Opt G1	1010 117 65446	96	18240	248 x 175 x 66
LinLED 156x28mm 800lm 930 2C 12V Opt G1	1010 127 07046	96	18240	248 x 175 x 66
LinLED 156x28mm 800lm 940 2C 12V Opt G1	1010 117 75446	96	18240	248 x 175 x 66