

Round LED modules 580mm

Product description

- Long life-time
- Built-in, constant current LED module
- Re-workable push-in terminals enabling easy connection
- Compliance and approval: CE, ENEC
- Available CCT from 2200K to 6500K and CRI 80, 90

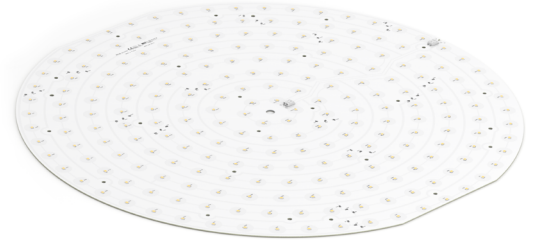

RdLED CRI 80 Optimum G3

Product name	Ordering code	Colour temperature [K]	Current nominal If nom [mA]	Luminous flux ¹ φ [lm]	Useful luminous flux ² [lm]	Voltage ¹ Vf [V]	Power ¹ P [W]	Efficacy ¹ [lm/W]	Current minimum If min ³ [mA]	Current maximum If max [mA]	Energy Efficiency Class
RdLED 580mm 8000lm 830 48V Opt G3	1010 117 83246	3000	980	7509	7748	44	43	175	140	2800	C
RdLED 580mm 8000lm 840 48V Opt G3	1010 117 83346	4000	980	8135	8394	44	43	190	140	2800	C

RdLED CRI 80 Optimum G2

Product name	Ordering code	Colour temperature [K]	Current nominal If nom [mA]	Luminous flux ¹ φ [lm]	Useful luminous flux ² [lm]	Voltage ¹ Vf [V]	Power ¹ P [W]	Efficacy ¹ [lm/W]	Current minimum If min ³ [mA]	Current maximum If max [mA]	Energy Efficiency Class
RdLED 580mm 8000lm 830 168V Opt G2	1010 117 53246	3000	290	7785	8026	156	45	173	40	600	C
RdLED 580mm 8000lm 830 48V Opt G2	1010 117 53046		1020	7821	8063	44	45	172	140	2100	C
RdLED 580mm 8000lm 840 168V Opt G2	1010 117 53346	4000	290	8183	8436	156	45	181	40	600	C
RdLED 580mm 8000lm 840 48V Opt G2	1010 117 53146		1020	8221	8475	44	45	181	140	2100	C

RdLED CRI 90 Optimum G2

Product name	Ordering code	Colour temperature [K]	Current nominal If nom [mA]	Luminous flux ¹ φ [lm]	Useful luminous flux ² [lm]	Voltage ¹ Vf [V]	Power ¹ P [W]	Efficacy ¹ [lm/W]	Current minimum If min ³ [mA]	Current maximum If max [mA]	Energy Efficiency Class
RdLED 580mm 8000lm 930 48V Opt G2	1010 117 98346	3000	1190	7770	8053	47	55	140	140	2100	E
RdLED 580mm 8000lm 940 48V Opt G2	1010 117 96046	4000	1190	8306	8608	47	55	150	140	2100	D

¹At nominal current and T_p

²At nominal current and 25°C

³It is recommended not to operate below minimum current in order to avoid un-even brightness

Tolerance range for optical and electrical ±10%

Temperature & humidity

Specification item	Unit	Value
T _p	[°C]	45
T _p rated	[°C]	65
T _c	[°C]	85
Relative humidity (non-condensing)	[%]	5 ... 85
Storage ambient temperature	[°C]	-25 ... +85
Storage relative humidity (non-condensing)	[%]	5 ... 85

T_p - Temperature related to the performance parameters of the LED modules

T_p rated - Maximum operating temperature to which the rated performance characteristics are declared

T_c - Highest permissible value for safe operation

Round LED modules 580mm

Technical data

Specification item	Unit	Value
Classification acc. to IEC 62031		built-in
Working voltage	[Vdc]	350
Beam angle	[deg]	120
Initial color consistency	[SDCM]	3
Photobiological safety		RG1 unlimited

Color coordinates

According to CIE 1931

Specification item	CIEx	CIEy
2700K	0.4578	0.4101
3000K	0.4338	0.4030
4000K	0.3818	0.3797
6500K	0.3123	0.3282

Certificates & standards

Specification item	Compliant
ENEC	Yes
CE	Yes
RoHS	Yes
REACH	Yes
Zhaga	No
IP rating	No IP rating

Lumen maintenance

RdLED CRI 80

Forward current	Tp temp.	L70 [h]		L80 [h]		L90 [h]	
		B50	B10	B50	B10	B50	B10
If nom	45°C	>72 000	>72 000	>72 000	>72 000	71 000	60 000
	55°C	>72 000	>72 000	>72 000	>72 000	71 000	60 000
	65°C	>72 000	>72 000	>72 000	>72 000	69 000	60 000
	75°C	>72 000	>72 000	>72 000	>72 000	68 000	58 000
	85°C	>72 000	>72 000	>72 000	>72 000	66 000	58 000
If max	45°C	>72 000	>72 000	>72 000	>72 000	49 000	38 000
	55°C	>72 000	>72 000	>72 000	>72 000	49 000	38 000
	65°C	>72 000	>72 000	>72 000	>72 000	49 000	38 000
	75°C	>72 000	>72 000	>72 000	>72 000	48 000	37 000
	85°C	>72 000	>72 000	>72 000	>72 000	48 000	37 000

reported data based on LM80 LED data (@65mA 17000h / @160mA & 200mA 12000h)

RdLED CRI 90

Forward current	Tp temp.	L70 [h]		L80 [h]		L90 [h]	
		B50	B10	B50	B10	B50	B10
If nom	45°C	>60 000	>60 000	>60 000	>60 000	58 000	>56 000
	65°C	>60 000	>60 000	>60 000	>60 000	47 000	46 000
	85°C	>60 000	>60 000	>60 000	>60 000	38 000	33 000
If max	45°C	>60 000	>60 000	52 000	49 000	29 000	28 000
	65°C	>60 000	>60 000	47 000	44 000	25 000	24 000
	85°C	>60 000	58 000	41 000	38 000	22 000	19 000

reported data based on LM80 LED data 10 000h

RdLED CRI 80

for RdLED CRI 80 Optimum G2

Forward current	Tp temp.	L70 [h]		L80 [h]		L90 [h]	
		B50	B10	B50	B10	B50	B10
If nom	45°C	>60 000	>60 000	>60 000	>60 000	44 000	39 000
	65°C	>60 000	>60 000	>60 000	>60 000	34 000	29 000
	85°C	>60 000	>60 000	>60 000	59 000	29 000	25 000
If max	45°C	>60 000	>60 000	>60 000	>60 000	40 000	32 000
	65°C	>60 000	>60 000	>60 000	>60 000	30 000	27 000
	85°C	>60 000	>60 000	>60 000	55 000	25 000	25 000

reported data based on LM80 LED data 10 000h

Round LED modules 580mm

Dimensions

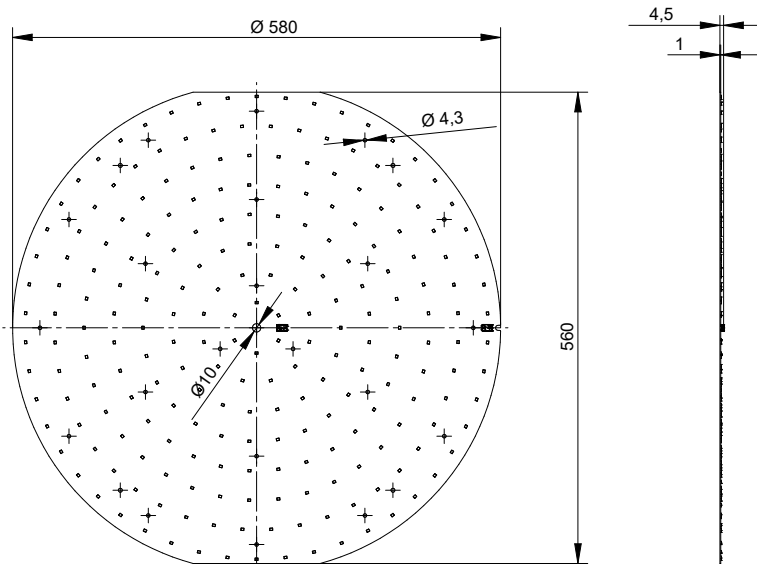

Mounting

LED Modules cannot be exposed to tensile or compressive stresses. For this purpose it is necessary that the modules are assembled to a flat surface by only rounded head screws. Additionally plastic flat washer should be used to ensure creepage distance between screw's head and surface of the pcb. Max. torque for fixing: 0,5Nm.

LED modules are sensitive to electrostatic discharge (ESD). Follow safety regulations according to IEC 61340-5-1.

Wiring

Wire cross section and strip length:

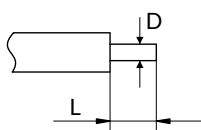

D - wire cross section (solid and flexible wires)	Min	Max
	0.2mm ²	0.75mm ²
	AWG 24	AWG 18

L - strip length	Min	Max
	8mm	9mm

Opening for the release of wires from the top with release pin Electroterminal art. 881 167 884:



Round LED modules 580mm

Connections

Wiring for series connection system

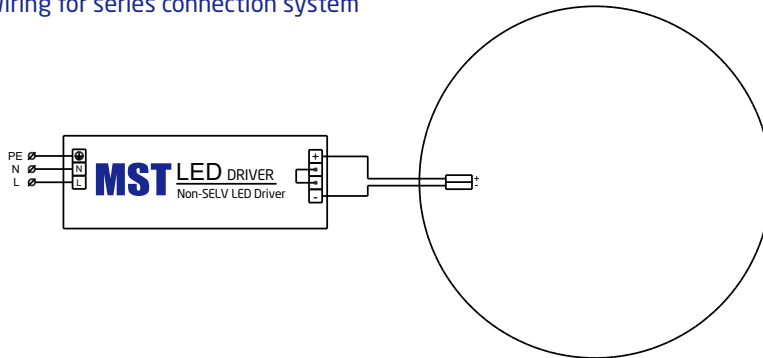

Wiring for parallel connection system

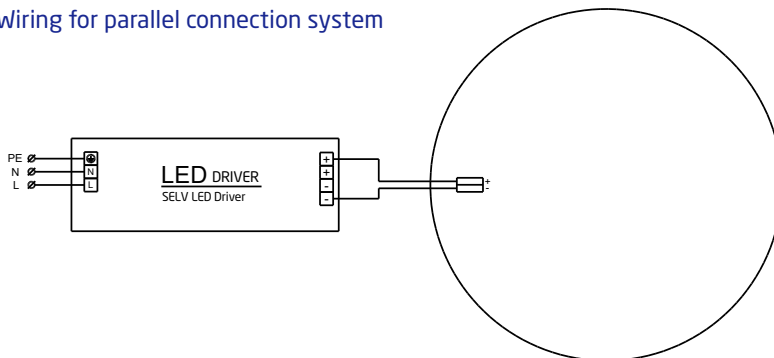

Energy Label / EPREL database

To obtain Energy Label for this product visit <https://eprel.ec.europa.eu/> and enter model identifier

Model identifier consists of 10 digits XXXX XXX XXX. It is printed directly on the LED module or on product label. This is the number you can see in EPREL database.

Ordering code consist of 12 digits XXXX XXX XXX46. Additional last two digits means packaging of the product.

Ordering codes

Product name	Ordering code	Pieces per box	Pieces per pallet	Box dimensions [mm]
RdLED 580mm 8000lm 830 48V Opt G3	1010 117 83246	12	240	593 x 593 x 58
RdLED 580mm 8000lm 840 48V Opt G3	1010 117 83346	12	240	593 x 593 x 58
RdLED 580mm 8000lm 830 168V Opt G2	1010 117 53246	12	240	593 x 593 x 58
RdLED 580mm 8000lm 830 48V Opt G2	1010 117 53046	12	240	593 x 593 x 58
RdLED 580mm 8000lm 840 168V Opt G2	1010 117 53346	12	240	593 x 593 x 58
RdLED 580mm 8000lm 840 48V Opt G2	1010 117 53146	12	240	593 x 593 x 58
RdLED 580mm 8000lm 930 48V Opt G2	1010 117 98346	12	240	593 x 593 x 58
RdLED 580mm 8000lm 940 48V Opt G2	1010 117 96046	12	240	593 x 593 x 58