

Linear LED modules 550lm/1ft 4C

Product description

- Long life-time
- Built-in, constant current LED module
- Re-workable push-in terminals enabling easy connection
- Compliance and approval: CE, ENEC
- 4C - four connectors for parallel system, also recognized as a low voltage system - SELV
- Available CCT from 2700K to 6500K and CRI 80, 90



LinLED CRI 80 Optimum G2

Product name	Ordering code	Colour temperature [K]	Current nominal If nom [mA]	Luminous flux ¹ φ [lm]	Useful luminous flux ² [lm]	Voltage ¹ Vf [V]	Power ¹ P [W]	Efficacy ¹ [lm/W]	Current minimum If min ³ [mA]	Current maximum If max [mA]	Energy Efficiency Class
LinLED 280x20mm 550lm 830 4C 36V Opt G2	1010 117 94446	3000	90	529	548	35	3.1	170	10	150	C
LinLED 560x20mm 1100lm 830 4C 36V Opt G2	1010 117 94546		180	1057	1095	35	6.2	170	20	300	C
LinLED 280x20mm 550lm 840 4C 36V Opt G2	1010 117 94646	4000	90	553	573	35	3.1	178	10	150	C
LinLED 560x20mm 1100lm 840 4C 36V Opt G2	1010 117 94746		180	1107	1147	35	6.2	178	20	300	C

¹At nominal current and T_p

²At nominal current and 25°C

³It is recommended not to operate below minimum current in order to avoid un-even brightness

Tolerance range for optical and electrical ±10%

Temperature & humidity

Specification item	Unit	Value
T _p	[°C]	45
T _{p rated}	[°C]	65
T _c	[°C]	85
Relative humidity (non-condensing)	[%]	5 ... 85
Storage ambient temperature	[°C]	-25 ... +85
Storage relative humidity (non-condensing)	[%]	5 ... 85

T_p - Temperature related to the performance parameters of the LED modules

T_{p rated} - Maximum operating temperature to which the rated performance characteristics are declared

T_c - Highest permissible value for safe operation

Technical data

Specification item	Unit	Value
Classification acc. to IEC 62031		built-in
Working voltage	[Vdc]	60
Beam angle	[deg]	120
Initial color consistency	[SDCM]	3
Photobiological safety		RG1 unlimited

Color coordinates

According to CIE 1931

Specification item	CIE _x	CIE _y
2700K	0.4578	0.4101
3000K	0.4338	0.4030
4000K	0.3818	0.3797
6500K	0.3123	0.3282

Linear LED modules 550lm/1ft 4C

Certificates & standards

Specification item	Compliant
ENEC	Yes
CE	Yes
RoHS	Yes
REACH	Yes
Zhaga	Comply with Book 7
IP rating	No IP rating

Lumen maintenance

LinLED CRI 80

Forward current	Tp temp.	L70 [h]		L80 [h]		L90 [h]	
		B50	B10	B50	B10	B50	B10
If nom	45°C	>72 000	>72 000	>72 000	>72 000	66 000	55 000
	55°C	>72 000	>72 000	>72 000	>72 000	66 000	55 000
	65°C	>72 000	>72 000	>72 000	>72 000	64 000	54 000
	75°C	>72 000	>72 000	>72 000	>72 000	62 000	53 000
	85°C	>72 000	>72 000	>72 000	>72 000	61 000	52 000
If max	45°C	>72 000	>72 000	>72 000	>72 000	51 000	39 000
	55°C	>72 000	>72 000	>72 000	>72 000	51 000	39 000
	65°C	>72 000	>72 000	>72 000	>72 000	48 000	37 000
	75°C	>72 000	>72 000	>72 000	>72 000	45 000	35 000
	85°C	>72 000	>72 000	>72 000	69 000	43 000	34 000

reported data based on LM80 LED data (@65mA 17000h / @160mA & 200mA 12000h)

Dimensions

LinLED 280x20mm

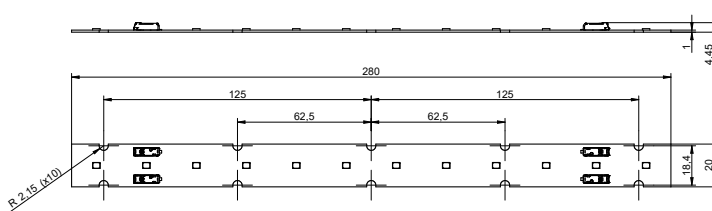

LinLED 560x20mm

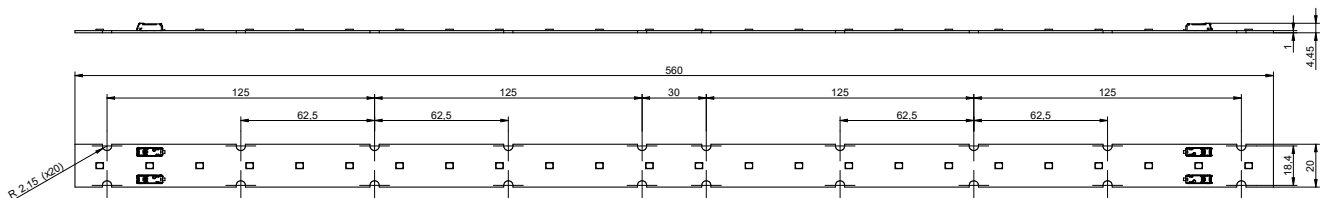

Mounting

LED Modules cannot be exposed to tensile or compressive stresses. For this purpose it is necessary that the modules are assembled to a flat surface by only rounded head screws. Additionally plastic flat washer should be used to ensure creepage distance between screw's head and surface of the pcb. Max. torque for fixing: 0,5Nm.

LED modules are sensitive to electrostatic discharge (ESD). Follow safety regulations according to IEC 61340-5-1.

Linear LED modules 550lm/1ft 4C

Wiring

Wire cross section and strip length:

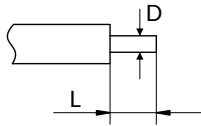

D - wire cross section (solid and flexible wires)	Min	Max
	0.2mm ² AWG 24	0.75mm ² AWG 18

L - strip length	Min	Max
	8mm	9mm

Opening for the release of wires from the top with release pin Electroterminal art. 881 167 884:



Connections

Max number of modules	Unit	Series	Parallel
LinLED 280x20mm	[pcs]	-	6
LinLED 560x20mm	[pcs]	-	3

Wiring for parallel connection system (4C)

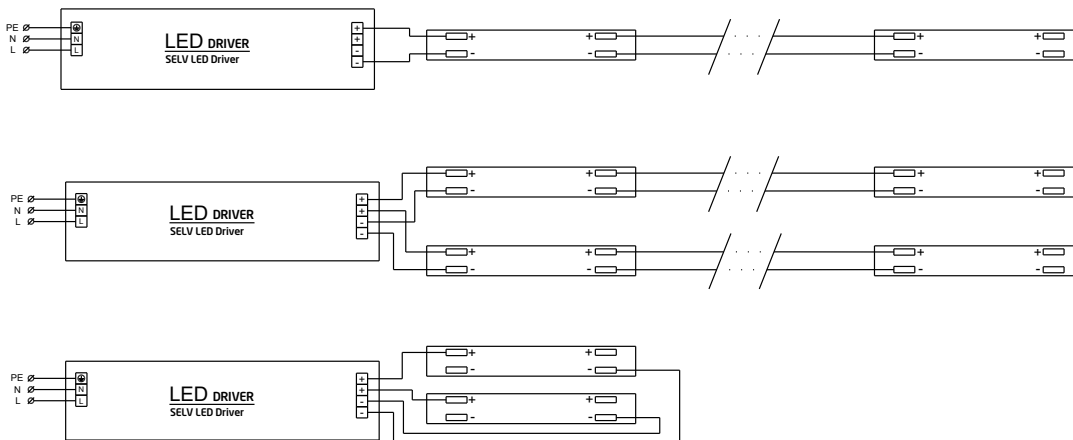

To prevent irregular luminous intensity in parallel connection use only LED modules from the same V-code group. V-code (e.g. *A*, *B*, *AB*) is printed on the LED module and box label. Naming is not adequate to efficacy or luminous flux.

Energy Label / EPREL database

To obtain Energy Label for this product visit <https://eprel.ec.europa.eu/> and enter model identifier

Model identifier consists of 10 digits XXXX XXX XXX. It is printed directly on the LED module or on product label. This is the number you can see in EPREL database.

Ordering code consist of 12 digits XXXX XXX XXX46. Additional last two digits means packaging of the product.

Ordering codes

Product name	Ordering code	Pieces per box	Pieces per pallet	Box dimensions [mm]
LinLED 280x20mm 550lm 830 4C 36V Opt G2	1010 117 94446	187	20196	298 x 238 x 88
LinLED 560x20mm 1100lm 830 4C 36V Opt G2	1010 117 94546	154	8624	594 x 303 x 58
LinLED 280x20mm 550lm 840 4C 36V Opt G2	1010 117 94646	187	20196	298 x 238 x 88
LinLED 560x20mm 1100lm 840 4C 36V Opt G2	1010 117 94746	154	8624	594 x 303 x 58