

## Linear LED modules DAISY-7X1 4C

A linear solution for premium class indoor lighting. Optimized for LEDi's DAISY-7X1 optics. Compatible with BRIANNA optics.

### Product description

- Long life-time
- Built-in, constant current LED module
- Re-workable push-in terminals enabling easy connection
- Compliance and approval: CE, ENEC
- 4C - four connectors for parallel system, also recognized as a low voltage system - SELV
- Available CCT from 2700K to 6500K and CRI 80, 90



### LinLED 4C CRI 80 ZT25 1100lm

Product name	Ordering code	Colour temperature [K]	Current nominal If nom [mA]	Luminous flux <sup>1</sup> φ [lm]	Useful luminous flux <sup>2</sup> [lm]	Voltage <sup>1</sup> Vf [V]	Power <sup>1</sup> P [W]	Efficacy <sup>1</sup> [lm/W]	Current minimum If min <sup>3</sup> [mA]	Current maximum If max [mA]	Energy Efficiency Class
LinLED 274x24mm 1100lm 830 4C 42V DAISY-7X1(ZT25) G4	1010 137 17346	3000K	160	1097	1124	39	6.3	174	10	450	C
LinLED 274x24mm 1100lm 840 4C 42V DAISY-7X1(ZT25) G4	1010 137 17446	4000K	160	1141	1169	39	6.3	181	10	450	C

### LinLED 4C CRI 80 ZT25 1600lm

Product name	Ordering code	Colour temperature [K]	Current nominal If nom [mA]	Luminous flux <sup>1</sup> φ [lm]	Useful luminous flux <sup>2</sup> [lm]	Voltage <sup>1</sup> Vf [V]	Power <sup>1</sup> P [W]	Efficacy <sup>1</sup> [lm/W]	Current minimum If min <sup>3</sup> [mA]	Current maximum If max [mA]	Energy Efficiency Class
LinLED 280x28mm 1600lm 830 4C 21V DAISY-7X1(ZT25)	1010 127 17846	3000	540	1548	1638	19	10	148	10	1500	D
LinLED 280x28mm 1600lm 840 4C 21V DAISY-7X1(ZT25)	1010 127 17946	4000	540	1629	1723	19	10	156	10	1500	D

### LinLED 4C CRI 80 G1

Product name	Ordering code	Colour temperature [K]	Current nominal If nom [mA]	Luminous flux <sup>1</sup> φ [lm]	Useful luminous flux <sup>2</sup> [lm]	Voltage <sup>1</sup> Vf [V]	Power <sup>1</sup> P [W]	Efficacy <sup>1</sup> [lm/W]	Current minimum If min <sup>3</sup> [mA]	Current maximum If max [mA]	Energy Efficiency Class
LinLED 280x28mm 1100lm 830 4C 42V DAISY-7X1 G1	1010 117 89246	3000	165	1107	1145	38	6.3	176	20	300	C
LinLED 560x28mm 2200lm 830 4C 42V DAISY-7X1 G1	1010 127 08946		330	2213	2290	38	13	176	40	600	C
LinLED 280x28mm 1100lm 840 4C 42V DAISY-7X1 G1	1010 117 81446	4000	165	1162	1203	38	6.3	184	20	300	C
LinLED 560x28mm 2200lm 840 4C 42V DAISY-7X1 G1	1010 127 09046		330	2325	2405	38	13	184	40	600	C

### LinLED 4C CRI 90 G1

Product name	Ordering code	Colour temperature [K]	Current nominal If nom [mA]	Luminous flux <sup>1</sup> φ [lm]	Useful luminous flux <sup>2</sup> [lm]	Voltage <sup>1</sup> Vf [V]	Power <sup>1</sup> P [W]	Efficacy <sup>1</sup> [lm/W]	Current minimum If min <sup>3</sup> [mA]	Current maximum If max [mA]	Energy Efficiency Class
LinLED 280x28mm 1100lm 927 4C 42V DAISY-7X1 G1	1010 117 89346	2700	185	972	1008	41	7.6	128	20	300	E
LinLED 280x28mm 1100lm 930 4C 42V DAISY-7X1 G1	1010 117 89446	3000	185	1044	1082	41	7.6	137	20	300	D
LinLED 280x28mm 1100lm 940 4C 42V DAISY-7X1 G1	1010 117 81546	4000	185	1116	1157	41	7.6	147	20	300	D

<sup>1</sup>At nominal current and T<sub>p</sub>

<sup>2</sup>At nominal current and 25°C

<sup>3</sup>It is recommended not to operate below minimum current in order to avoid un-even brightness  
Tolerance range for optical and electrical ±10%

## Linear LED modules DAISY-7X1 4C

### Temperature & humidity

Specification item	Unit	Value
Tp	[°C]	45 / 65*
Tp rated	[°C]	65
Tc	[°C]	85
Relative humidity (non-condensing)	[%]	5 ... 85
Storage ambient temperature	[°C]	-25 ... +85
Storage relative humidity (non-condensing)	[%]	5 ... 85

Tp - Temperature related to the performance parameters of the LED modules

Tp rated - Maximum operating temperature to which the rated performance characteristics are declared

Tc - Highest permissible value for safe operation

\* for LinLED 4C CRI 80 ZT25

### Technical data

Specification item	Unit	Value
Classification acc. to IEC 62031		built-in
Working voltage	[Vdc]	60
Beam angle	[deg]	120
Initial color consistency	[SDCM]	3
Photobiological safety		RG1 unlimited

### Color coordinates

According to CIE 1931

Specification item	CIE <sub>x</sub>	CIE <sub>y</sub>
2700K	0.4578	0.4101
3000K	0.4338	0.4030
4000K	0.3818	0.3797
6500K	0.3123	0.3282

### Certificates & standards

Specification item	4C ZT25 1600lm	ZT25 1100lm
ENEC	Yes	No
CE	Yes	Yes
RoHS	Yes	Yes
REACH	Yes	Yes
Zhaga	No	No
IP rating	No IP rating	No IP rating

### Lumen maintenance

#### LinLED CRI 80

#### LinLED CRI 90

Forward current	Tp temp.	L70 [h]		L80 [h]		L90 [h]	
		B50	B10	B50	B10	B50	B10
If nom	45°C	>72 000	>72 000	>72 000	>72 000	67 000	57 000
	55°C	>72 000	>72 000	>72 000	>72 000	67 000	57 000
	65°C	>72 000	>72 000	>72 000	>72 000	65 000	56 000
	75°C	>72 000	>72 000	>72 000	>72 000	64 000	54 000
	85°C	>72 000	>72 000	>72 000	>72 000	62 000	54 000
If max	45°C	>72 000	>72 000	>72 000	>72 000	51 000	39 000
	55°C	>72 000	>72 000	>72 000	>72 000	51 000	39 000
	65°C	>72 000	>72 000	>72 000	>72 000	48 000	37 000
	75°C	>72 000	>72 000	>72 000	>72 000	45 000	35 000
	85°C	>72 000	>72 000	>72 000	69 000	43 000	34 000

reported data based on LM80 LED data (@65mA 17000h / @160mA & 200mA 12000h)

Forward current	Tp temp.	L70 [h]		L80 [h]		L90 [h]	
		B50	B10	B50	B10	B50	B10
If nom	45°C	>60 000	>60 000	>60 000	>60 000	55 000	53 000
	55°C	>60 000	>60 000	>60 000	>60 000	44 000	43 000
If max	45°C	>60 000	>60 000	52 000	49 000	29 000	28 000
	55°C	>60 000	>60 000	47 000	44 000	25 000	24 000
	65°C	>60 000	58 000	41 000	38 000	22 000	19 000

reported data based on LM80 LED data (10 000h)

## Linear LED modules DAISY-7X1 4C

### LinLED CRI 80

for LinLED 4C CRI 80 ZT25

Forward current	Tp temp.	L70 [h]		L80 [h]		L90 [h]	
		B50	B10	B50	B10	B50	B10
If nom	55°C	>102 000	>102 000	>102 000	>102 000	>102 000	>100 000
	65°C	>102 000	>102 000	>102 000	>102 000	>102 000	>95 000
	75°C	>102 000	>102 000	>102 000	>102 000	>102 000	>89 000
	85°C	>102 000	>102 000	>102 000	>102 000	>102 000	>85 000

reported data based on LM80 LED data (17 000h)

### Dimensions

#### LinLED 274x24mm

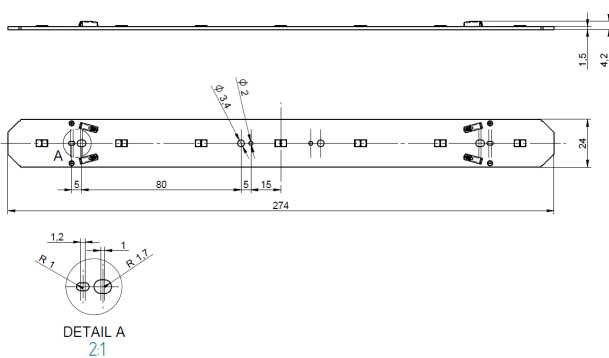

#### LinLED 280x28mm

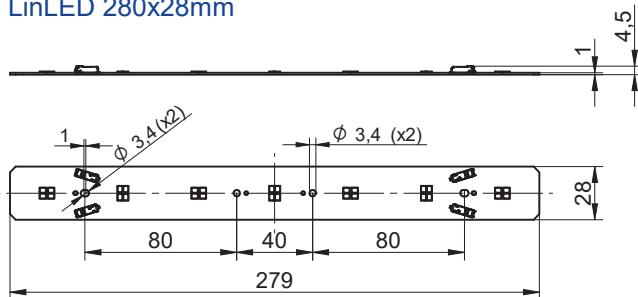

#### LinLED 4C CRI 80 ZT25

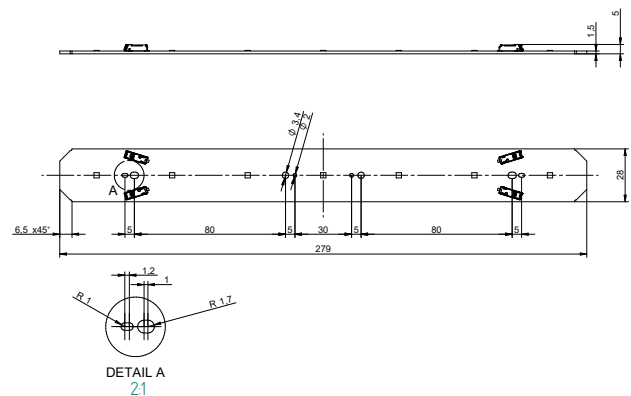

#### LinLED 560x28mm

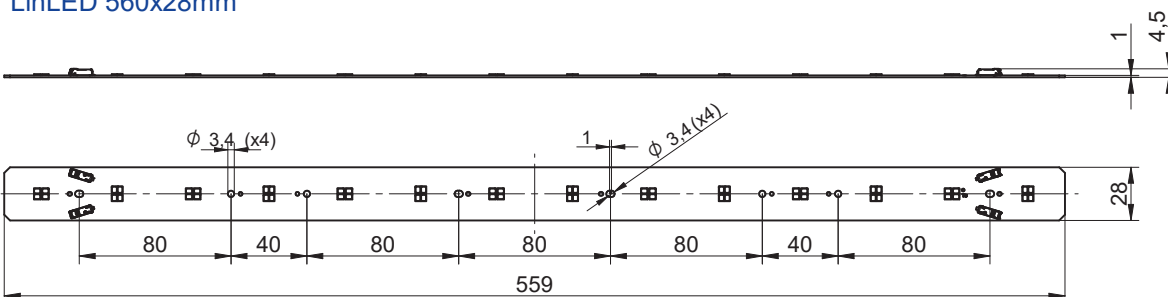

## Linear LED modules DAISY-7X1 4C

### Mounting

LED Modules cannot be exposed to tensile or compressive stresses. For this purpose it is necessary that the modules are assembled to a flat surface by only rounded head screws. Additionally plastic flat washer should be used to ensure creepage distance between screw's head and surface of the pcb. Max. torque for fixing: 0,5Nm.

LED modules are sensitive to electrostatic discharge (ESD). Follow safety regulations according to IEC 61340-5-1.

### Wiring

Wire cross section and strip length:

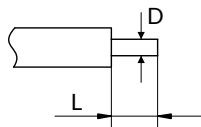

D - wire cross section (solid and flexible wires)	Min	Max
	0.2mm <sup>2</sup>	0.75mm <sup>2</sup>
	AWG 24	AWG 18

L - strip length	Min	Max
	8mm	9mm

Opening for the release of wires from the top with release pin Electroterminal art. 881 167 884:



### Connections

Max number of modules	Unit	Series	Parallel
LinLED 274x24mm...	[pcs]	-	8
LinLED 280x28mm...	[pcs]	-	6
LinLED 560x28mm...	[pcs]	-	3

### Wiring for parallel connection system (4C)

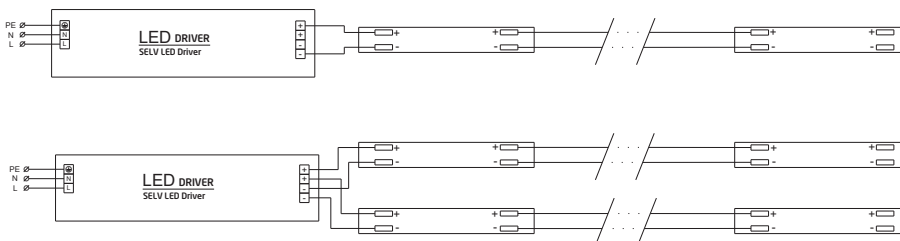

To prevent irregular luminous intensity in parallel connection use only LED modules from the same V-code group.  
V-code (e.g. "A", "B", "AB") is printed on the LED module and box label. Naming is not adequate to efficacy or luminous flux.

### Energy Label / EPREL database

To obtain Energy Label for this product visit <https://eprel.ec.europa.eu/> and enter model identifier

Model identifier consists of 10 digits XXXX XXX XXX. It is printed directly on the LED module or on product label. This is the number you can see in EPREL database.

Ordering code consist of 12 digits XXXX XXX XXX46. Additional last two digits means packaging of the product.

## Linear LED modules DAISY-7X1 4C

### Ordering codes

Product name	Ordering code	Pieces per box	Pieces per pallet	Box dimensions [mm]
LinLED 274x24mm 1100lm 830 4C 42V DAISY-7X1(ZT25) G4	1010 137 17346	150	18000	300 x 266 x 83
LinLED 274x24mm 1100lm 840 4C 42V DAISY-7X1(ZT25) G4	1010 137 17446	150	18000	300 x 266 x 83
LinLED 280x28mm 1600lm 830 4C 21V DAISY-7X1(ZT25)	1010 127 17846	117	14040	300 x 266 x 83
LinLED 280x28mm 1600lm 840 4C 21V DAISY-7X1(ZT25)	1010 127 17946	117	14040	300 x 266 x 83
LinLED 280x28mm 1100lm 830 4C 42V DAISY-7X1 G1	1010 117 89246	117	14040	300 x 266 x 83
LinLED 560x28mm 2200lm 830 4C 42V DAISY-7X1 G1	1010 127 08946	135	8100	603 x 266 x 83
LinLED 280x28mm 1100lm 840 4C 42V DAISY-7X1 G1	1010 117 81446	117	14040	300 x 266 x 83
LinLED 560x28mm 2200lm 840 4C 42V DAISY-7X1 G1	1010 127 09046	135	8100	603 x 266 x 83
LinLED 280x28mm 1100lm 927 4C 42V DAISY-7X1 G1	1010 117 89346	117	14040	300 x 266 x 83
LinLED 280x28mm 1100lm 930 4C 42V DAISY-7X1 G1	1010 117 89446	117	14040	300 x 266 x 83
LinLED 280x28mm 1100lm 940 4C 42V DAISY-7X1 G1	1010 117 81546	117	14040	300 x 266 x 83