

## Outdoor LED modules 3535

A rectangular solution for outdoor lighting. Compatible with standard 2x2 optics for example LEDIL's STRADA-2x2

### Product description

- Long life-time
- Built-in, constant current LED module
- Re-workable push-in terminals enabling easy connection
- Compliance and approval: CE
- Available CCT from 2200K to 6500K and CRI 70, 75, 80, 90



### RecLED 3535 CRI 70 Optimum G1

Product name	Ordering code	Colour temperature [K]	Current nominal If nom [mA]	Luminous flux <sup>1</sup> φ [lm]	Useful luminous flux <sup>2</sup> [lm]	Voltage <sup>1</sup> Vf [V]	Power <sup>1</sup> P [W]	Efficacy <sup>1</sup> [lm/W]	Current minimum If min <sup>3</sup> [mA]	Current maximum If max [mA]	Energy Efficiency Class
RecLED 122x50mm 1900lm 718 2x4 3535 Opt G1	1010 127 31546	1800	520	1370	1491	22	12	118	100	1500	E
RecLED 173x50mm 2900lm 718 2x6 3535 Opt G1	1010 127 29446	1800	520	2055	2236	34	17	118	100	1500	E
RecLED 224x50mm 3800lm 718 2x8 3535 Opt G1	1010 127 29546	1800	520	2741	2982	45	23	118	100	1500	E

### RecLED 122x50mm 2x4 3535 CRI 70 Optimum G2

Product name	Ordering code	Colour temperature [K]	Current nominal If nom [mA]	Luminous flux <sup>1</sup> φ [lm]	Useful luminous flux <sup>2</sup> [lm]	Voltage <sup>1</sup> Vf [V]	Power <sup>1</sup> P [W]	Efficacy <sup>1</sup> [lm/W]	Current minimum If min <sup>3</sup> [mA]	Current maximum If max [mA]	Energy Efficiency Class
RecLED 122x50mm 1900lm 730 2x4 3535 Opt G2	1010 117 28246	3000	500	1862	2006	22	11	168	100	1500	B
RecLED 122x50mm 1900lm 740 2x4 3535 Opt G2	1010 117 28346	4000	500	1978	2132	22	11	179	100	1500	B

### RecLED 173x50mm 2x6 3535 CRI 70 Optimum G2

Product name	Ordering code	Colour temperature [K]	Current nominal If nom [mA]	Luminous flux <sup>1</sup> φ [lm]	Useful luminous flux <sup>2</sup> [lm]	Voltage <sup>1</sup> Vf [V]	Power <sup>1</sup> P [W]	Efficacy <sup>1</sup> [lm/W]	Current minimum If min <sup>3</sup> [mA]	Current maximum If max [mA]	Energy Efficiency Class
RecLED 173x50mm 2900lm 730 2x6 3535 Opt G2	1010 117 28746	3000	500	2793	3010	33	17	168	100	1500	B
RecLED 173x50mm 2900lm 740 2x6 3535 Opt G2	1010 117 28846	4000	500	2968	3198	33	17	179	100	1500	B

### RecLED 224x50mm 2x8 3535 CRI 70 Optimum G2

Product name	Ordering code	Colour temperature [K]	Current nominal If nom [mA]	Luminous flux <sup>1</sup> φ [lm]	Useful luminous flux <sup>2</sup> [lm]	Voltage <sup>1</sup> Vf [V]	Power <sup>1</sup> P [W]	Efficacy <sup>1</sup> [lm/W]	Current minimum If min <sup>3</sup> [mA]	Current maximum If max [mA]	Energy Efficiency Class
RecLED 224x50mm 3800lm 730 2x8 3535 Opt G2	1010 117 29246	3000	500	3724	4013	44	22	168	100	1500	B
RecLED 224x50mm 3800lm 740 2x8 3535 Opt G2	1010 117 29346	4000	500	3957	4264	44	22	179	100	1500	B

<sup>1</sup>At nominal current and T<sub>p</sub>

<sup>2</sup>At nominal current and 25°C

<sup>3</sup>It is recommended not to operate below minimum current in order to avoid un-even brightness

Tolerance range for optical and electrical ±10%

### Temperature & humidity

Specification item	Unit	Value
T <sub>p</sub>	[°C]	75
T <sub>p rated</sub>	[°C]	75
T <sub>c</sub>	[°C]	95
Relative humidity (non-condensing)	[%]	5 ... 85
Storage ambient temperature	[°C]	-25 ... +85
Storage relative humidity (non-condensing)	[%]	5 ... 85

T<sub>p</sub> - Temperature related to the performance parameters of the LED modules

T<sub>p rated</sub> - Maximum operating temperature to which the rated performance characteristics are declared

T<sub>c</sub> - Highest permissible value for safe operation

## Outdoor LED modules 3535

### Technical data

Specification item	Unit	Value
Classification acc. to IEC 62031		built-in
Working voltage	[Vdc]	420
Beam angle	[deg]	128
Initial color consistency	[SDCM]	5
Photobiological safety		RG1

### Color coordinates

According to CIE 1931

Specification item	CIEx	CIEy
1800K	0.5500	0.4080
2700K	0.4578	0.4101
3000K	0.4338	0.4030
4000K	0.3818	0.3797
6500K	0.3123	0.3282

### Certificates & standards

Specification item	Compliant
ENEC	Yes
CE	Yes
RoHS	Yes
REACH	Yes
Zhaga	Comply with Book 15
IP rating	No IP rating

### Lumen maintenance

### RecLED CRI 70

Forward current	Tp temp.	L70 [h]		L80 [h]		L90 [h]	
		B50	B10	B50	B10	B50	B10
If nom	75°C	>100 000	>100 000	>100 000	>100 000	>100 000	>100 000
	80°C	>100 000	>100 000	>100 000	>100 000	>100 000	>100 000
	85°C	>100 000	>100 000	>100 000	>100 000	>100 000	>100 000
	90°C	>100 000	>100 000	>100 000	>100 000	>100 000	>100 000
	95°C	>100 000	>100 000	>100 000	>100 000	>100 000	>100 000

simulation based on LM80 LED data 10 000h

## Outdoor LED modules 3535

### Dimensions

RecLED 122x50mm 2x4

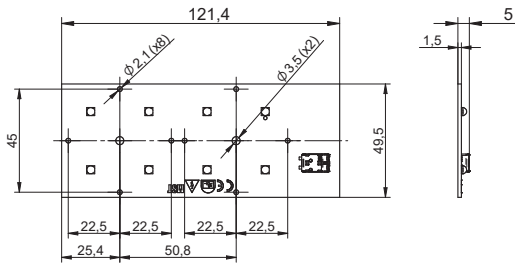

RecLED 173x50mm 2x6

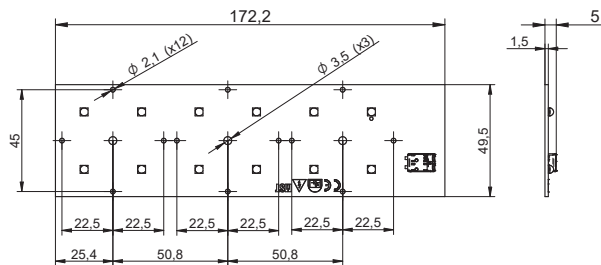

RecLED 224x50mm 2x8

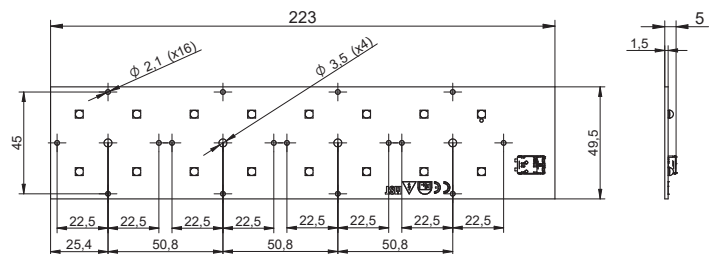

### Mounting

LED Modules cannot be exposed to tensile or compressive stresses. For this purpose it is necessary that the modules are assembled to a flat surface by only rounded head screws. Additionally plastic flat washer should be used to ensure creepage distance between screw's head and surface of the pcb. Max. torque for fixing: 0,5Nm.

LED modules are sensitive to electrostatic discharge (ESD). Follow safety regulations according to IEC 61340-5-1.

### Wiring

Wire cross section and strip length:

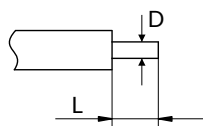

D - wire cross section (solid and flexible wires)	Min	Max
	0.2mm <sup>2</sup>	0.75mm <sup>2</sup>
	AWG 24	AWG 18

L - strip length	Min	Max
	8mm	9mm

Opening for the release of wires from the top with release pin Electroterminal art. 881 167 884:



## Outdoor LED modules 3535

### Connections

Max number of modules	Unit	Series	Parallel
RecLED 122x50mm 2x4 3535	[pcs]	17	-
RecLED 173x50mm 2x6 3535	[pcs]	11	-
RecLED 224x50mm 2x8 3535	[pcs]	8	-

### Wiring for series connection system

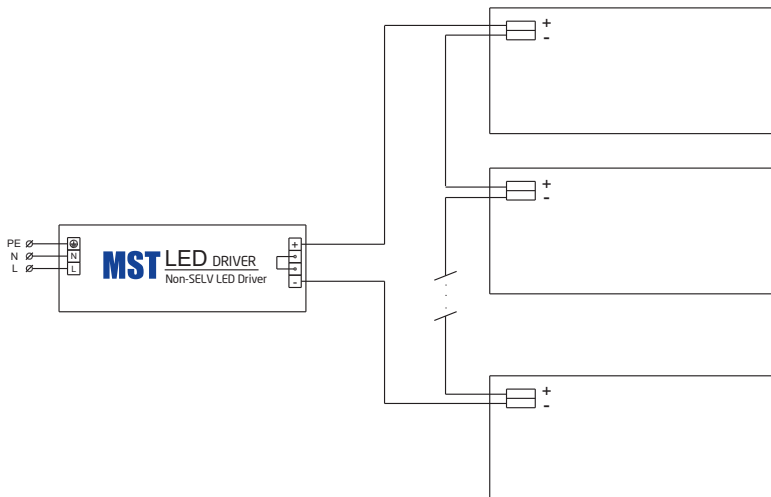

### Energy Label / EPREL database

To obtain Energy Label for this product visit <https://eprel.ec.europa.eu/> and enter model identifier

Model identifier consists of 10 digits XXXX XXX XXX. It is printed directly on the LED module or on product label. This is the number you can see in EPREL database.

Ordering code consist of 12 digits XXXX XXX XXX46. Additional last two digits means packaging of the product.

### Ordering codes

Product name	Ordering code	Pieces per box	Pieces per pallet	Box dimensions [mm]
RecLED 122x50mm 1900lm 718 2x4 3535 Opt G1	1010 127 31546	40	11520	238 x 140 x 61
RecLED 173x50mm 2900lm 718 2x6 3535 Opt G1	1010 127 29446	64	8640	238x 238 x 91
RecLED 224x50mm 3800lm 718 2x8 3535 Opt G1	1010 127 29546	36	6840	248 x 175 x 66
RecLED 122x50mm 1900lm 730 2x4 3535 Opt G2	1010 117 28246	40	11520	238 x 140 x 61
RecLED 122x50mm 1900lm 740 2x4 3535 Opt G2	1010 117 28346	40	11520	238 x 140 x 61
RecLED 173x50mm 2900lm 730 2x6 3535 Opt G2	1010 117 28746	64	8640	238x 238 x 91
RecLED 173x50mm 2900lm 740 2x6 3535 Opt G2	1010 117 28846	64	8640	238 x 238 x 91
RecLED 224x50mm 3800lm 730 2x8 3535 Opt G2	1010 117 29246	36	6840	248 x 175 x 66
RecLED 224x50mm 3800lm 740 2x8 3535 Opt G2	1010 117 29346	36	6840	248 x 175 x 66