

## High Bay LED modules 250mm

### Product description

- Long life-time
- Built-in, constant current LED module
- Re-workable push-in terminals enabling easy connection
- Compliance and approval: CE
- Available CCT from 2700K to 6500K and CRI 80, 90

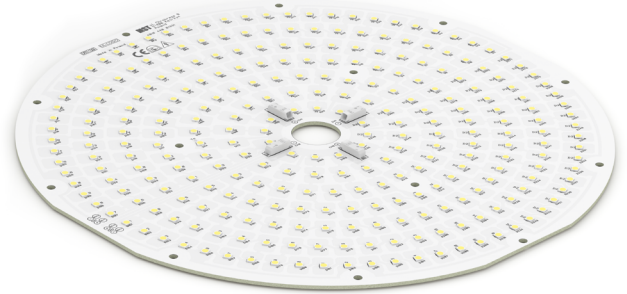

### RdLED CRI 80 Optimum G1

Product name	Ordering code	Colour temperature [K]	Current nominal If nom [mA]	Luminous flux <sup>1</sup> φ [lm]	Useful luminous flux <sup>2</sup> [lm]	Voltage <sup>1</sup> Vf [V]	Power <sup>1</sup> P [W]	Efficacy <sup>1</sup> [lm/W]	Current minimum If min <sup>3</sup> [mA]	Current maximum If max [mA]	Energy Efficiency Class
RdED 250mm 2x13000lm 840 170W 2x84V Opt G1	1010 117 64346	4000	1050	13044	14109	81	85	153	100	2000	D
			1050	13044	14109	81	85	153	100	2000	D

<sup>1</sup>At nominal current and T<sub>p</sub>

<sup>2</sup>At nominal current and 25°C

<sup>3</sup>It is recommended not to operate below minimum current in order to avoid un-even brightness

Tolerance range for optical and electrical ±10%

### Temperature & humidity

Specification item	Unit	Value
T <sub>p</sub>	[°C]	65
T <sub>p</sub> rated	[°C]	65
T <sub>c</sub>	[°C]	85
Relative humidity (non-condensing)	[%]	5 ... 85
Storage ambient temperature	[°C]	-25 ... +85
Storage relative humidity (non-condensing)	[%]	5 ... 85

T<sub>p</sub> - Temperature related to the performance parameters of the LED modules

T<sub>p</sub> rated - Maximum operating temperature to which the rated performance characteristics are declared

T<sub>c</sub> - Highest permissible value for safe operation

### Technical data

Specification item	Unit	Value
Classification acc. to IEC 62031		built-in
Beam angle	[deg]	120
Initial color consistency	[SDCM]	3
Photobiological safety		RG1 unlimited

### Color coordinates

According to CIE 1931

Specification item	CIE <sub>x</sub>	CIE <sub>y</sub>
2700K	0.4578	0.4101
3000K	0.4338	0.4030
4000K	0.3818	0.3797
6500K	0.3123	0.3282

## High Bay LED modules 250mm

### Certificates & standards

Specification item	Compliant
ENEC	No
CE	Yes
RoHS	Yes
REACH	Yes
Zhaga	No
IP rating	No IP rating

### Lumen maintenance

### RdLED CRI 80

Forward current	Tp temp.	L70 [h]		L80 [h]		L90 [h]	
		B50	B10	B50	B10	B50	B10
	45°C	>60 000	>60 000	>60 000	>60 000	52 000	46 000
If nom	65°C	>60 000	>60 000	>60 000	>60 000	50 000	44 000
	85°C	>60 000	>60 000	>60 000	>60 000	46 000	40 000

reported data based on LM80 LED data 10 000h

### Dimensions

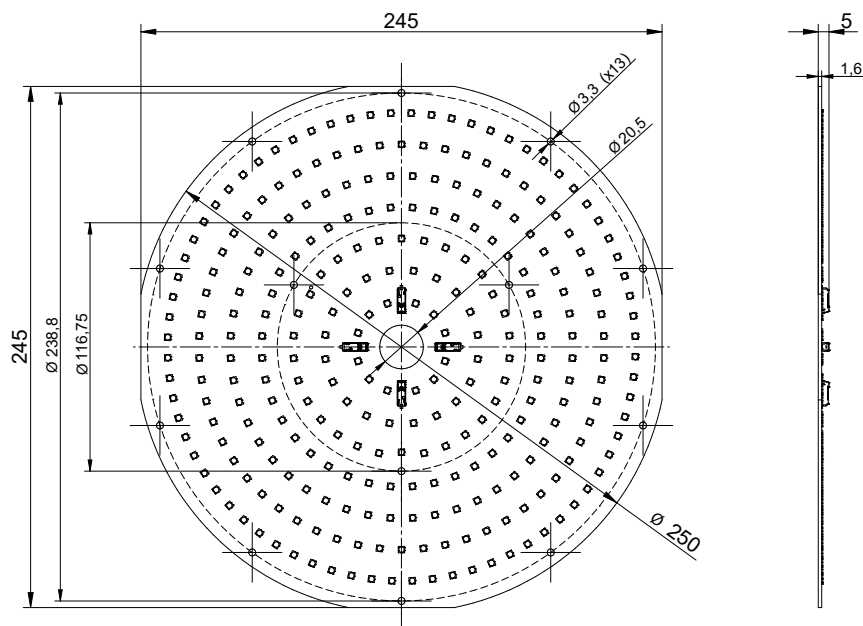

### Mounting

LED Modules cannot be exposed to tensile or compressive stresses. For this purpose it is necessary that the modules are assembled to a flat surface by only rounded head screws. Additionally plastic flat washer should be used to ensure creepeage distance between screw's head and surface of the pcb. Max. torque for fixing: 0,5Nm.

LED modules are sensitive to electrostatic discharge (ESD). Follow safety regulations according to IEC 61340-5-1.

## High Bay LED modules 250mm

### Wiring

Wire cross section and strip length:

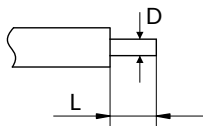

D - wire cross section (solid and flexible wires)	Min	Max
	0.2mm <sup>2</sup>	0.75mm <sup>2</sup>
	AWG 24	AWG 18

L - strip length	Min	Max
	8mm	9mm

Opening for the release of wires from the top  
with release pin Electroterminal art. 881 167 884:



### Connections

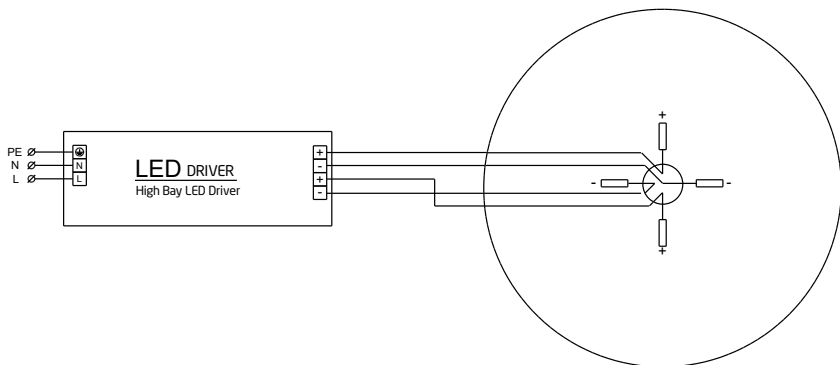

### Energy Label / EPREL database

To obtain Energy Label for this product visit <https://eprel.ec.europa.eu/> and enter model identifier

Model identifier consists of 10 digits XXXX XXX XXX. It is printed directly on the LED module or on product label. This is the number you can see in EPREL database.

Ordering code consist of 12 digits XXXX XXX XXX46. Additional last two digits means packaging of the product.

### Ordering codes

Product name	Ordering code	Pieces per box	Pieces per pallet	Box dimensions [mm]
RdLED 250mm 2x1300lm 840 170W 2x84V Opt G1	1010 117 64346	16	1344	261 x 261 x 103