

## Linear LED modules 1100lm 12V per 1ft 2C+R

### Product description

- Long life-time
- Built-in, constant current LED module
- Re-workable push-in terminals enabling easy connection
- Compliance and approval: CE
- 2C+R - two connectors for series system, with integrated return path (two additional connectors) also recognized as a high voltage system - non-SELV
- Available CCT from 2200K to 6500K and CRI 80, 90
- Perfect solution for long linear lighting systems (trunking or long profiles) with easy wiring
- Low voltage of modules provides great flexibility in selection of LED Drivers



### LinLED CRI 80 Opt G5

Product name	Ordering code	Colour temperature [K]	Current nominal If nom [mA]	Luminous flux <sup>1</sup> φ [lm]	Useful luminous flux <sup>2</sup> [lm]	Voltage <sup>1</sup> Vf [V]	Power <sup>1</sup> P [W]	Efficacy <sup>1</sup> [lm/W]	Current minimum If min <sup>3</sup> [mA]	Current maximum If max [mA]	Energy Efficiency Class
LinLED 70x24mm 275lm 830 2C+R 3V Opt G5	1010 127 99346	3000	525	268	275	2.7	1.4	191	80	2400	C
LinLED 140x24mm 550lm 830 2C+R 6V Opt G5	1010 127 99446		525	537	551	5.4	2.8	191	80	2400	C
LinLED 280x24mm 1100lm 830 2C+R 12V Opt G5	1010 127 99546		525	1074	1102	11	5.6	191	80	2400	C
LinLED 560x24mm 2200lm 830 2C+R 24V Opt G5	1010 127 99646		525	2147	2203	22	11	191	80	2400	C
LinLED 1120x24mm 4400lm 830 2C+R 48V Opt G5	1010 127 99746		525	4295	4407	43	23	191	80	2400	C
LinLED 1400x24mm 5500lm 830 2C+R 60V Opt G5	1010 127 99846		525	5368	5509	54	28	191	80	2400	C
LinLED 70x24mm 275lm 840 2C+R 3V Opt G5	1010 127 99946	4000	525	286	294	2.7	1.4	204	80	2400	B
LinLED 140x24mm 550lm 840 2C+R 6V Opt G5	1010 137 00146		525	573	588	5.4	2.8	204	80	2400	B
LinLED 280x24mm 1100lm 840 2C+R 12V Opt G5	1010 137 00246		525	1145	1175	11	5.6	204	80	2400	B
LinLED 560x24mm 2200lm 840 2C+R 24V Opt G5	1010 137 00346		525	2291	2350	22	11	204	80	2400	B
LinLED 1120x24mm 4400lm 840 2C+R 48V Opt G5	1010 137 00446		525	4581	4701	43	23	204	80	2400	B
LinLED 1400x24mm 5500lm 840 2C+R 60V Opt G5	1010 137 00546		525	5726	5876	54	28	204	80	2400	B

### LinLED CRI 80 Opt G4

Product name	Ordering code	Colour temperature [K]	Current nominal If nom [mA]	Luminous flux <sup>1</sup> φ [lm]	Useful luminous flux <sup>2</sup> [lm]	Voltage <sup>1</sup> Vf [V]	Power <sup>1</sup> P [W]	Efficacy <sup>1</sup> [lm/W]	Current minimum If min <sup>3</sup> [mA]	Current maximum If max [mA]	Energy Efficiency Class
LinLED 70x24mm 275lm 830 2C+R 3V Opt G4	1010 127 98146	3000	540	267	274	2.7	1.5	182	80	2400	C
LinLED 140x24mm 550lm 830 2C+R 6V Opt G4	1010 127 98246		540	534	548	5.4	2.9	182	80	2400	C
LinLED 280x24mm 1100lm 830 2C+R 12V Opt G4	1010 127 98346		540	1069	1096	11	5.9	182	80	2400	C
LinLED 560x24mm 2200lm 830 2C+R 24V Opt G4	1010 127 98446		540	2137	2191	22	12	182	80	2400	C
LinLED 1120x24mm 4400lm 830 2C+R 48V Opt G4	1010 127 98546		540	4274	4383	44	24	182	80	2400	C
LinLED 1400x24mm 5500lm 830 2C+R 60V Opt G4	1010 127 98646		540	5343	5479	54	29	182	80	2400	C
LinLED 70x24mm 275lm 840 2C+R 3V Opt G4	1010 127 98746	4000	540	286	293	2.7	1.5	194	80	2400	C
LinLED 140x24mm 550lm 840 2C+R 6V Opt G4	1010 127 98846		540	571	586	5.4	2.9	194	80	2400	B
LinLED 280x24mm 1100lm 840 2C+R 12V Opt G4	1010 127 98946		540	1142	1171	11	5.9	194	80	2400	B
LinLED 560x24mm 2200lm 840 2C+R 24V Opt G4	1010 127 99046		540	2284	2343	22	12	194	80	2400	B
LinLED 1120x24mm 4400lm 840 2C+R 48V Opt G4	1010 127 99146		540	4569	4685	44	24	194	80	2400	B
LinLED 1400x24mm 5500lm 840 2C+R 60V Opt G4	1010 127 99246		540	5711	5856	54	29	194	80	2400	B

## Linear LED modules 1100lm 12V per 1ft 2C+R

### LinLED CRI 80 Opt G1

Product name	Ordering code	Colour temperature [K]	Current nominal If nom [mA]	Luminous flux <sup>1</sup> φ [lm]	Useful luminous flux <sup>2</sup> [lm]	Voltage <sup>1</sup> Vf [V]	Power <sup>1</sup> P [W]	Efficacy <sup>1</sup> [lm/W]	Current minimum If min <sup>3</sup> [mA]	Current maximum If max [mA]	Energy Efficiency Class
LinLED 280x24mm 1100lm 827 2C+R 12V Opt G1	1010 127 88146	2700	560	1101	1141	11	6.2	178	80	1200	C
LinLED 560x24mm 2200lm 827 2C+R 24V Opt G1	1010 127 88246		560	2202	2282	22	12	178	80	1200	C
LinLED 70x24mm 275lm 830 2C+R 3V Opt G1	1010 127 71146		560	283	294	2.8	1.5	183	80	1200	C
LinLED 140x24mm 550lm 830 2C+R 6V Opt G1	1010 127 71246	3000	560	567	588	5.5	3.1	183	80	1200	C
LinLED 280x24mm 1100lm 830 2C+R 12V Opt G1	1010 127 71346		560	1134	1175	11	6.2	183	80	1200	C
LinLED 560x24mm 2200lm 830 2C+R 24V Opt G1	1010 127 71446		560	2268	2350	22	12	183	80	1200	C
LinLED 1120x24mm 4400lm 830 2C+R 48V Opt G1	1010 127 71546	4000	560	4536	4700	44	25	183	80	1200	C
LinLED 1400x24mm 5500lm 830 2C+R 60V Opt G1	1010 127 71646		560	5670	5876	55	31	183	80	1200	C
LinLED 70x24mm 275lm 840 2C+R 3V Opt G1	1010 127 71746		560	296	307	2.8	1.5	191	80	1200	C
LinLED 140x24mm 550lm 840 2C+R 6V Opt G1	1010 127 71846	4000	560	592	613	5.5	3.1	191	80	1200	C
LinLED 280x24mm 1100lm 840 2C+R 12V Opt G1	1010 127 71946		560	1183	1226	11	6.2	191	80	1200	C
LinLED 560x24mm 2200lm 840 2C+R 24V Opt G1	1010 127 72046		560	2366	2452	22	12	191	80	1200	C
LinLED 1120x24mm 4400lm 840 2C+R 48V Opt G1	1010 127 72146	4000	560	4733	4905	44	25	191	80	1200	C
LinLED 1400x24mm 5500lm 840 2C+R 60V Opt G1	1010 127 72246		560	5916	6131	55	31	191	80	1200	C

<sup>1</sup>At nominal current and T<sub>p</sub>

<sup>2</sup>At nominal current and 25°C

<sup>3</sup>It is recommended not to operate below minimum current in order to avoid un-even brightness

Tolerance range for optical and electrical ±10%

### Temperature & humidity

Specification item	Unit	Value
T <sub>p</sub>	[°C]	45
T <sub>p</sub> rated	[°C]	65
T <sub>c</sub>	[°C]	85
Relative humidity (non-condensing)	[%]	5 ... 85
Storage ambient temperature	[°C]	-25 ... +85
Storage relative humidity (non-condensing)	[%]	5 ... 85

T<sub>p</sub> - Temperature related to the performance parameters of the LED modules

T<sub>p</sub> rated - Maximum operating temperature to which the rated performance characteristics are declared

T<sub>c</sub> - Highest permissible value for safe operation

### Technical data

Specification item	Unit	Value
Classification acc. to IEC 62031		built-in
Working voltage	[Vdc]	350
Beam angle	[deg]	120
Initial color consistency	[SDCM]	3
Photobiological safety		RG1 unlimited

## Linear LED modules 1100lm 12V per 1ft 2C+R

### Color coordinates

According to CIE 1931

Specification item	CIE <sub>x</sub>	CIE <sub>y</sub>
2700K	0.4578	0.4101
3000K	0.4338	0.4030
4000K	0.3818	0.3797
6500K	0.3123	0.3282

### Certificates & standards

Specification item	Compliant
ENEC	No
CE	Yes
RoHS	Yes
REACH	Yes
IP rating	No IP rating

### Lumen maintenance

### LinLED CRI 80

Forward current	Tp temp.	L70 [h]		L80 [h]		L90 [h]	
		B50	B10	B50	B10	B50	B10
If nom	45°C	>100 000	>100 000	>100 000	>100 000	71 000	61 000
	55°C	>100 000	>100 000	>100 000	>100 000	71 000	61 000
	65°C	>100 000	>100 000	>100 000	>100 000	69 000	60 000
	75°C	>100 000	>100 000	>100 000	>100 000	68 000	59 000
	85°C	>100 000	>100 000	>100 000	>100 000	67 000	58 000
If max	45°C	>100 000	>100 000	>100 000	>100 000	51 000	39 000
	55°C	>100 000	>100 000	>100 000	>100 000	51 000	39 000
	65°C	>100 000	>100 000	>100 000	>100 000	48 000	37 000
	75°C	>100 000	>100 000	>100 000	>100 000	45 000	35 000
	85°C	>100 000	>100 000	>100 000	>100 000	43 000	34 000

calculated data based on LM80 LED data (@65mA 17000h / @160mA & 200mA 12000h)

### LinLED CRI 80

for LinLED CRI 80 Optimum G4 & G5

Forward current	Tp temp.	L70 [h]		L80 [h]		L90 [h]	
		B50	B10	B50	B10	B50	B10
If max	85°C	>100 000	>100 000	>100 000	>100 000	52 640	52 330

calculated data based on LM80 LED data 12000h

### Dimensions

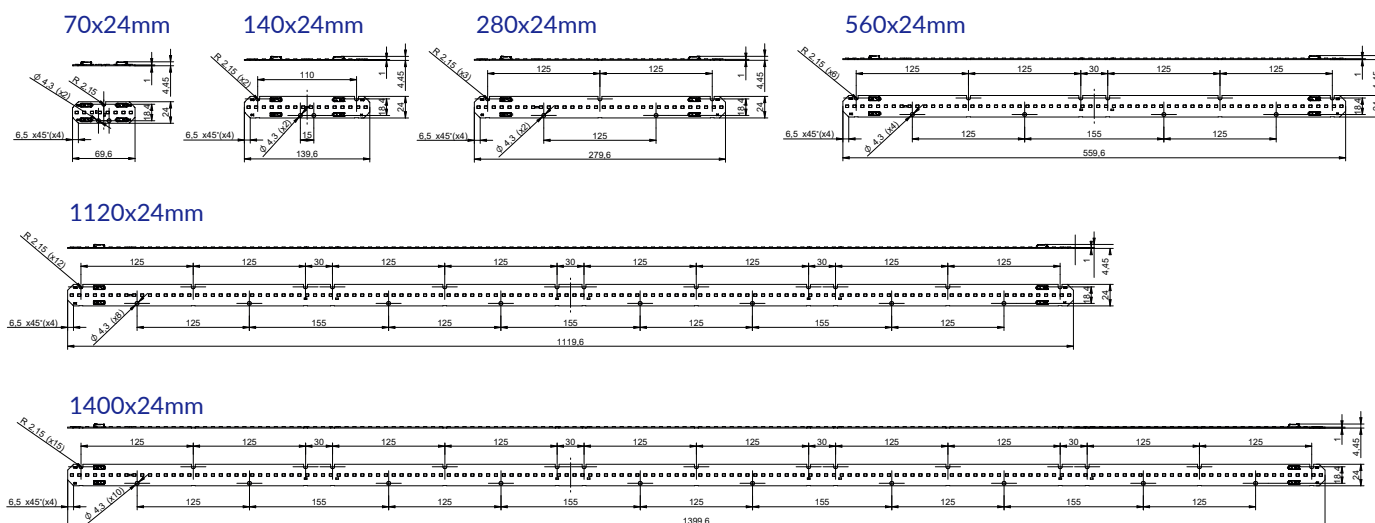

## Linear LED modules 1100lm 12V per 1ft 2C+R

### Mounting

LED Modules cannot be exposed to tensile or compressive stresses. For this purpose it is necessary that the modules are assembled to a flat surface by only rounded head screws. Additionally plastic flat washer should be used to ensure creepeage distance between screw's head and surface of the pcb. Max. torque for fixing: 0,5Nm.

LED modules are sensitive to electrostatic discharge (ESD). Follow safety regulations according to IEC 61340-5-1.

### Wiring

Wire cross section and strip length:

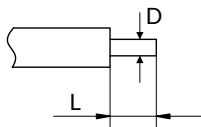

D - wire cross section (solid and flexible wires)	Min	Max
	0.2mm <sup>2</sup>	0.75mm <sup>2</sup>
	AWG 24	AWG 18

L - strip length	Min	Max
	8mm	9mm

Opening for the release of wires from the top with release pin Electroterminal art. 881 167 884:



### Connections

Max number of modules	Unit	Series	Parallel
LinLED 70x24mm	[pcs]	112	-
LinLED 140x24mm	[pcs]	56	-
LinLED 280x24mm	[pcs]	28	-
LinLED 560x24mm	[pcs]	14	-
LinLED 1120x24mm	[pcs]	7	-
LinLED 1400x24mm	[pcs]	5	-

You can combine different lengths of LED modules so that the maximum length does not exceed 7840mm

#### Wiring for series connection system with return path

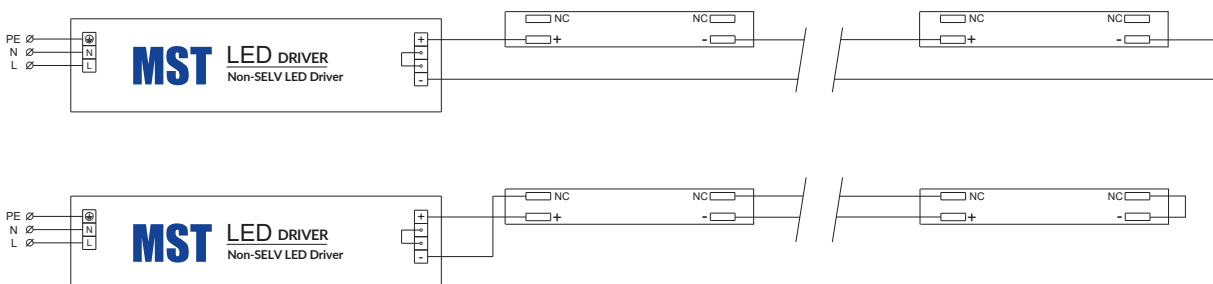

### Energy Label / EPREL database

To obtain Energy Label for this product visit <https://eprel.ec.europa.eu/> and enter model identifier

Model identifier consists of 10 digits XXXX XXX XXX. It is printed directly on the LED module or on product label. This is the number you can see in EPREL database.

Ordering code consist of 12 digits XXXX XXX XXX46. Additional last two digits means packaging of the product.

## Linear LED modules 1100lm 12V per 1ft 2C+R

### Ordering codes

Product name	Ordering code	Pieces per box	Pieces per pallet	Box dimensions [mm]
LinLED 70x24mm 275lm 830 2C+R 3V Opt G5	1010 127 99346	320	76800	150 x 266 x 83
LinLED 140x24mm 550lm 830 2C+R 6V Opt G5	1010 127 99446	108	24624	248 x 175 x 66
LinLED 280x24mm 1100lm 830 2C+R 12V Opt G5	1010 127 99546	150	18000	300 x 266 x 83
LinLED 560x24mm 2200lm 830 2C+R 24V Opt G5	1010 127 99646	160	9600	603 x 266 x 83
LinLED 1120x24mm 4400lm 830 2C+R 48V Opt G5	1010 127 99746	170	5100	1198 x 266 x 83
LinLED 1400x24mm 5500lm 830 2C+R 60V Opt G5	1010 127 99846	160	4800	1498 x 266 x 83
LinLED 70x24mm 275lm 840 2C+R 3V Opt G5	1010 127 99946	320	76800	150 x 266 x 83
LinLED 140x24mm 550lm 840 2C+R 6V Opt G5	1010 137 00146	108	24624	248 x 175 x 66
LinLED 280x24mm 1100lm 840 2C+R 12V Opt G5	1010 137 00246	150	18000	300 x 266 x 83
LinLED 560x24mm 2200lm 840 2C+R 24V Opt G5	1010 137 00346	160	9600	603 x 266 x 83
LinLED 1120x24mm 4400lm 840 2C+R 48V Opt G5	1010 137 00446	170	5100	1198 x 266 x 83
LinLED 1400x24mm 5500lm 840 2C+R 60V Opt G5	1010 137 00546	160	4800	1498 x 266 x 83
LinLED 70x24mm 275lm 830 2C+R 3V Opt G4	1010 127 98146	320	76800	150 x 266 x 83
LinLED 140x24mm 550lm 830 2C+R 6V Opt G4	1010 127 98246	108	24624	248 x 175 x 66
LinLED 280x24mm 1100lm 830 2C+R 12V Opt G4	1010 127 98346	150	18000	300 x 266 x 83
LinLED 560x24mm 2200lm 830 2C+R 24V Opt G4	1010 127 98446	160	9600	603 x 266 x 83
LinLED 1120x24mm 4400lm 830 2C+R 48V Opt G4	1010 127 98546	170	5100	1198 x 266 x 83
LinLED 1400x24mm 5500lm 830 2C+R 60V Opt G4	1010 127 98646	160	4800	1498 x 266 x 83
LinLED 70x24mm 275lm 840 2C+R 3V Opt G4	1010 127 98746	320	76800	150 x 266 x 83
LinLED 140x24mm 550lm 840 2C+R 6V Opt G4	1010 127 98846	108	24624	248 x 175 x 66
LinLED 280x24mm 1100lm 840 2C+R 12V Opt G4	1010 127 98946	150	18000	300 x 266 x 83
LinLED 560x24mm 2200lm 840 2C+R 24V Opt G4	1010 127 99046	160	9600	603 x 266 x 83
LinLED 1120x24mm 4400lm 840 2C+R 48V Opt G4	1010 127 99146	170	5100	1198 x 266 x 83
LinLED 1400x24mm 5500lm 840 2C+R 60V Opt G4	1010 127 99246	160	4800	1498 x 266 x 83
LinLED 280x24mm 1100lm 827 2C+R 12V Opt G1	1010 127 88146	150	18000	300 x 266 x 83
LinLED 560x24mm 2200lm 827 2C+R 24V Opt G1	1010 127 88246	160	9600	603 x 266 x 83
LinLED 70x24mm 275lm 830 2C+R 3V Opt G1	1010 127 71146	320	76800	150 x 266 x 83
LinLED 140x24mm 550lm 830 2C+R 6V Opt G1	1010 127 71246	108	24624	248 x 175 x 66
LinLED 280x24mm 1100lm 830 2C+R 12V Opt G1	1010 127 71346	150	18000	300 x 266 x 83
LinLED 560x24mm 2200lm 830 2C+R 24V Opt G1	1010 127 71446	160	9600	603 x 266 x 83
LinLED 1120x24mm 4400lm 830 2C+R 48V Opt G1	1010 127 71546	170	5100	1198 x 266 x 83
LinLED 1400x24mm 5500lm 830 2C+R 60V Opt G1	1010 127 71646	160	4800	1498 x 266 x 83
LinLED 70x24mm 275lm 840 2C+R 3V Opt G1	1010 127 71746	320	76800	150 x 266 x 83
LinLED 140x24mm 550lm 840 2C+R 6V Opt G1	1010 127 71846	108	24624	248 x 175 x 66
LinLED 280x24mm 1100lm 840 2C+R 12V Opt G1	1010 127 71946	150	18000	300 x 266 x 83
LinLED 560x24mm 2200lm 840 2C+R 24V Opt G1	1010 127 72046	160	9600	603 x 266 x 83
LinLED 1120x24mm 4400lm 840 2C+R 48V Opt G1	1010 127 72146	170	5100	1198 x 266 x 83
LinLED 1400x24mm 5500lm 840 2C+R 60V Opt G1	1010 127 72246	160	4800	1498 x 266 x 83