

Linear LED modules DAISY-7X1 & DAISY-28X1 2C

A linear solution for premium class indoor lighting. Optimized for LEDi's DAISY-7X1 & DAISY-28X1 optics. Compatible with BRIANNA optics.

Product description

- Long life-time
- Built-in, constant current LED module
- Re-workable push-in terminals enabling easy connection
- Compliance and approval: CE, ENEC
- 2C - two connectors for series system, also recognized as a high voltage system - non-SELV
- Other CCT and CRI on request



The image shows version 2C. The number of connectors may vary depending on the type of module.



LinLED CRI 80 CJ G4

Product name	Ordering code	Colour temperature [K]	Current nominal If nom [mA]	Luminous flux ¹ φ [lm]	Useful luminous flux ² [lm]	Voltage ¹ Vf [V]	Power ¹ P [W]	Efficacy ¹ [lm/W]	Current minimum If min ³ [mA]	Current maximum If max [mA]	Energy Efficiency Class
LinLED 280x28mm 2x550lm 827-865 2x2C 42V DAISY-7X1 CJ G4	1010 137 33046	2700	80	532	545	38	3.0	176	10	300	C
		6500	80	589	604	38	3.0	195	10	300	
LinLED 280x28mm 1100lm 830 2C 42V DAISY-7X1 CJ G4	1010 137 33146	3000	150	1072	1099	38	5.6	190	20	600	C
LinLED 280x28mm 1100lm 840 2C 42V DAISY-7X1 CJ G4	1010 137 33246	4000	150	1114	1143	38	5.6	197	20	600	B

LinLED CRI 90 S8 K G7

Product name	Ordering code	Colour temperature [K]	Current nominal If nom [mA]	Luminous flux ¹ φ [lm]	Useful luminous flux ² [lm]	Voltage ¹ Vf [V]	Power ¹ P [W]	Efficacy ¹ [lm/W]	Current minimum If min ³ [mA]	Current maximum If max [mA]	Energy Efficiency Class
LinLED 280x28mm 2x550lm 927-965 2x2C 42V DAISY-7X1 S8 K G7	1010 147 86046	2700	80	560	570	38	3.0	185	10	150	C
		6500	80	596	607	38	3.0	197	10	150	

LinLED CRI 90 EH1.1 G3

Product name	Ordering code	Colour temperature [K]	Current nominal If nom [mA]	Luminous flux ¹ φ [lm]	Useful luminous flux ² [lm]	Voltage ¹ Vf [V]	Power ¹ P [W]	Efficacy ¹ [lm/W]	Current minimum If min ³ [mA]	Current maximum If max [mA]	Energy Efficiency Class
LinLED 280x28mm 1100lm 930 2C 42V DAISY-7X1 EH1.1 G3	1010 127 02846	3000	185	1044	1082	41	7.6	137	20	300	E
LinLED 280x28mm 1100lm 940 2C 42V DAISY-7X1 EH1.1 G3	1010 117 83646	4000	185	1116	1157	41	7.6	147	20	300	D

¹At nominal current and T_p

²At nominal current and 25°C

³It is recommended not to operate below minimum current in order to avoid un-even brightness

Tolerance range for optical and electrical ±10%

Temperature & humidity

Specification item	Unit	Value
T _p	[°C]	45
T _p rated	[°C]	65
T _c	[°C]	85
Relative humidity (non-condensing)	[%]	5 ... 85
Storage ambient temperature	[°C]	-25 ... +85
Storage relative humidity (non-condensing)	[%]	5 ... 85

T_p - Temperature related to the performance parameters of the LED modules

T_p rated - Maximum operating temperature to which the rated performance characteristics are declared

T_c - Highest permissible value for safe operation

Linear LED modules DAISY-7X1 & DAISY-28X1 2C

Technical data

Specification item	Unit	Value
Classification acc. to IEC 62031		built-in
Working voltage	[Vdc]	260
Beam angle	[deg]	120
Initial color consistency	[SDCM]	3
Photobiological safety		RG1 unlimited

Color coordinates

According to CIE 1931

Specification item	CIEx	CIEy
2700K	0.4578	0.4101
3000K	0.4338	0.4030
4000K	0.3818	0.3797
6500K	0.3123	0.3282

Certificates & standards

Specification item	Compliant
ENEC	Yes
CE	Yes
RoHS	Yes
REACH	Yes
IP rating	No IP rating

Lumen maintenance

for CJ G4

Forward current	Tp temp.	L70 [h]		L80 [h]		L90 [h]	
		B50	B10	B50	B10	B50	B10
If nom	45°C	>102 000	>102 000	>102 000	>102 000	>102 000	>102 000
	55°C	>102 000	>102 000	>102 000	>102 000	>102 000	>102 000
	65°C	>102 000	>102 000	>102 000	>102 000	87 000	86 000
	75°C	>102 000	>102 000	>102 000	>102 000	74 000	73 000
	85°C	>102 000	>102 000	>102 000	>102 000	63 000	62 000
If max	45°C	>102 000	>102 000	>102 000	>102 000	>102 000	>102 000
	55°C	>102 000	>102 000	>102 000	>102 000	90 000	89 000
	65°C	>102 000	>102 000	>102 000	>102 000	77 000	76 000
	75°C	>102 000	>102 000	>102 000	>102 000	65 000	64 000
	85°C	>102 000	>102 000	>102 000	>102 000	55 000	54 000

reported data based on LM80 LED data (17000h)

for S8 K G7, S7 K G7, S5 K G6

Forward current	Tp temp.	L70 [h]		L80 [h]		L90 [h]	
		B50	B10	B50	B10	B50	B10
If nom	45°C	>120 000	>120 000	117 000	114 000	62 000	61 000
	55°C	>120 000	>120 000	96 000	94 000	50 000	49 000
	65°C	>120 000	>120 000	80 000	78 000	41 000	40 000
	75°C	104 000	102 000	67 000	65 000	34 000	33 000
	85°C	89 000	87 000	56 000	55 000	28 000	27 000
If max	45°C	>120 000	>120 000	85 000	82 000	45 000	44 000
	55°C	108 000	104 000	69 000	68 000	36 000	35 000
	65°C	90 000	87 000	57 000	56 000	29 000	29 000
	75°C	75 000	74 000	48 000	47 000	24 000	24 000
	85°C	64 000	63 000	41 000	40 000	20 000	20 000

Calculated data based on LM80 LED data (20 000h)

for EH1.1 G3

Forward current	Tp temp.	L70 [h]		L80 [h]		L90 [h]	
		B50	B10	B50	B10	B50	B10
If nom	45°C	>60 000	>60 000	>60 000	>60 000	55 000	53 000
	55°C	>60 000	>60 000	>60 000	>60 000	44 000	43 000
	65°C	>60 000	>60 000	>60 000	>60 000	36 000	32 000
If max	45°C	>60 000	>60 000	52 000	49 000	29 000	28 000
	55°C	>60 000	>60 000	47 000	44 000	25 000	24 000
	65°C	>60 000	58 000	41 000	38 000	22 000	19 000

reported data based on LM80 LED data (10 000h)

Linear LED modules DAISY-7X1 & DAISY-28X1 2C

Dimensions

Product name	Ordering code	Connectors (*)
LinLED 280x28mm ... 2x2C	1010 137 33046	Yes
LinLED 280x28mm ... 2C	1010 137 33146	No

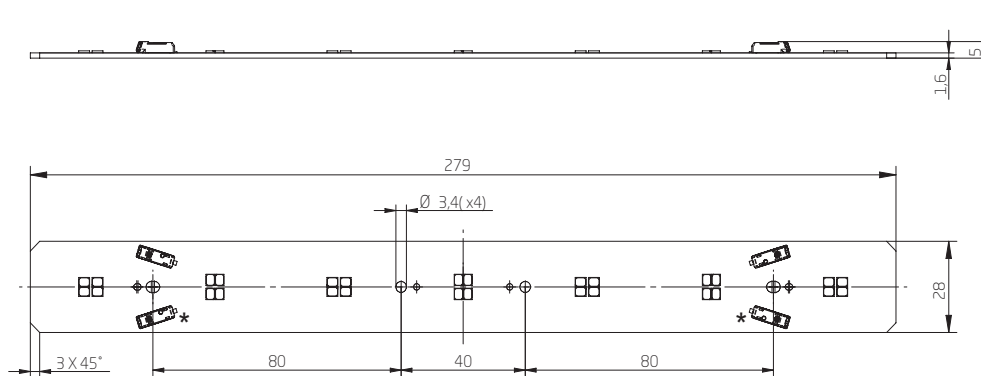

Mounting

LED Modules cannot be exposed to tensile or compressive stresses. For this purpose it is necessary that the modules are assembled to a flat surface by only rounded head screws. Additionally plastic flat washer should be used to ensure creepage distance between screw's head and surface of the pcb. Max. torque for fixing: 0,5Nm.

LED modules are sensitive to electrostatic discharge (ESD). Follow safety regulations according to IEC 61340-5-1.

Protection against electric shock must be provided by the luminaire's enclosure.

Wiring

Wire cross section and strip length:

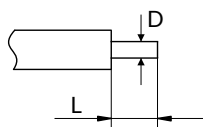

D - wire cross section (solid and flexible wires)	Min	Max
	0.2mm ²	0.75mm ²
	AWG 24	AWG 18

L - strip length	Min	Max
	8mm	9mm

Opening for the release of wires from the top with release pin Electroterminal art. 881 167 884:



Linear LED modules DAISY-7X1 & DAISY-28X1 2C

Connections

Max number of modules	Unit	Series	Parallel
LinLED 280x28mm...	[pcs]	6	-

Wiring for series connection system (2C)

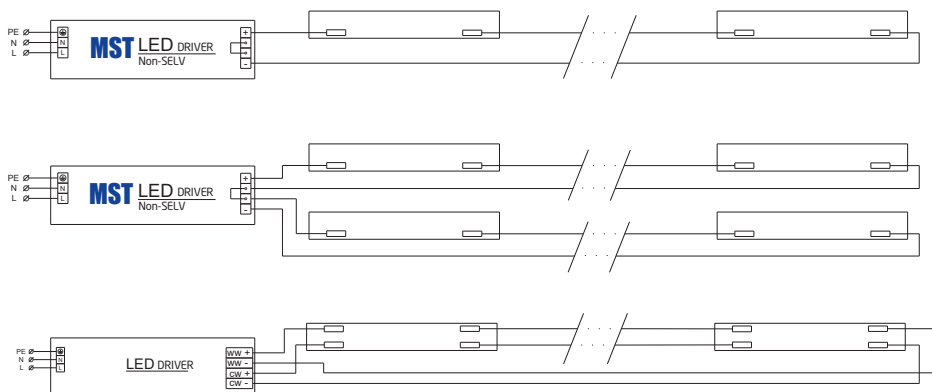

Energy Label / EPREL database

To obtain Energy Label for this product visit <https://eprel.ec.europa.eu/> and enter model identifier

Model identifier consists of 10 digits XXXX XXX XXX. It is printed directly on the LED module or on product label. This is the number you can see in EPREL database.

Ordering code consist of 12 digits XXXX XXX XXX46. Additional last two digits means packaging of the product.

Ordering codes

Product name	Ordering code	Pieces per box	Pieces per pallet	Box dimensions [mm]
LinLED 280x28mm 2x550lm 827-865 2x2C 42V DAISY-7X1 CJ G4	1010 137 33046	126	15120	300 x 266 x 83
LinLED 280x28mm 1100lm 830 2C 42V DAISY-7X1 CJ G4	1010 137 33146	135	16200	300 x 266 x 83
LinLED 280x28mm 1100lm 840 2C 42V DAISY-7X1 CJ G4	1010 137 33246	135	16200	300 x 266 x 83
LinLED 280x28mm 2x550lm 927-965 2x2C 42V DAISY-7X1 S7 K G7	1010 147 86046	126	15120	300 x 266 x 83
LinLED 280x28mm 1100lm 930 2C 42V DAISY-7X1 EH1.1 G3	1010 127 02846	135	16200	300 x 266 x 83
LinLED 280x28mm 1100lm 940 2C 42V DAISY-7X1 EH1.1 G3	1010 117 83646	135	16200	300 x 266 x 83